

# PCM260(WTL01) Submersible Level Transmitter

## Features

- Piezoresistive diffused silicon pressure sensor
- Probe insertion measurement method, easy to install
- For level measurement
- Multiple protective structure design, high protection ability
- LCD option
- Variety of styles, suitable for various industrial applications
- Anti-corrosion stainless steel material adopted, suitable for many occasions

## Applications

- Static pressure level
- Liquid tanks
- Sewage
- Industrial water
- Pools
- Wells
- Rivers
- Seawater
- Lakes

### Notes:

- 1 Do not touch the diaphragm with hard objects, which may cause damage to the diaphragm.
- 2 Please read the Instruction Manual of the product carefully before installation and check the relevant information of the product.
- 3 Strictly follow the wiring method for wiring, otherwise it may cause product damage or other potential faults.
- 4 Misuse of the product may cause danger or personal injury.



## Product overview

PCM260(WTL01) Submersible Level Transmitter accurately measures static pressure of the liquid proportional to the level depth using high performance piezoresistive diffused silicon pressure sensor as the measuring element. The result is converted to standard current or voltage signal output through signal conditioning circuit, establishing the linear corresponding relation between the output signal and liquid depth to complete the measurement of the liquid depth. The product has advantages of high precision and small volume. Submerge it directly into liquid, the height between the end of the transmitter to the liquid surface is measured easily. The product is applicable to the measurement and control of the liquid level in the petroleum, chemical industry, power plant, urban water supply and hydrological exploration fields.

PCM260 has passed long-term aging and stability screening with stable and reliable performance and can be used in harsh outdoor environment. Meanwhile, it can display liquid level on site. Zero shift and full scale span shift available.

### Notes:

- 1 Do not misuse documentation.
- 2 The information presented in this product sheet is for reference only. Do not use this document as a product installation guide.
- 3 Complete installation, operation, and maintenance information is provided in the instructions of the product.
- 4 Misuse of the product may cause danger or personal injury.

**Performance parameters**

Pressure range	0~1m...5m...10mH <sub>2</sub> O. Other pressure range can be customized.
Supply & output	For 2088 housing without the display: code J1, you can choose: (18~36V, 24V typical) output 4~20mA

	For cable outlet without 2088: code J3 / 2088 housing with the display: code J2, you can choose: (12~36V, 24V typical) output 4~20mA
	Cable outlet without 2088 housing: code J3, you can choose digital circuit board, analogue circuit board, others can be customized.
Operating temp.	-20°C~85°C
Medium temp.	-10°C~70°C
Storage temp.	-40°C~125°C
Zero temp. coefficient	±1.5%FS (within compensated temp.)
Span temp. coefficient	±1.5%FS (within compensated temp.)
Overpressure	200%FS~300%FS
Mechanical vibration	20g (20~5000HZ)
Shock	100g (11ms)
Accuracy	0.5%FS
Insulation	200MΩ/250VDC
Response time	≤1ms (Up to 90%FS analogue circuit board), ≤100ms (Up to 90%FS digital circuit board)
Long term stability	±0.2%FS/year
Protection	IP68
Material	Low copper aluminum alloy for junction box; stainless steel for level probe Polyurethane wire for cable
Medium compatibility	All kinds of media compatible with stainless steel 304

### Electrical connection

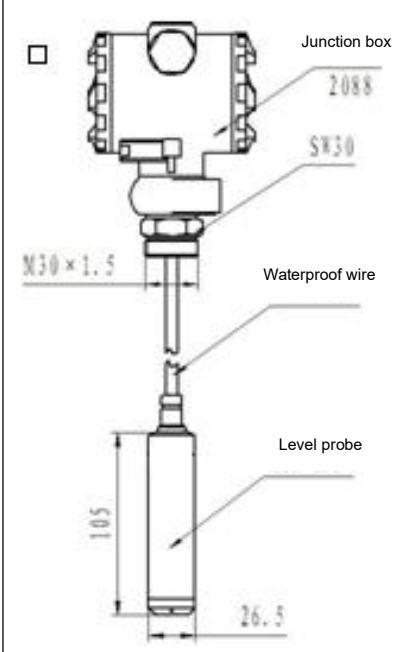
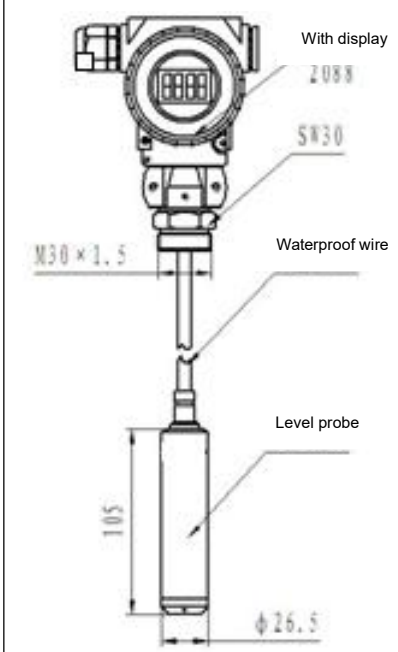
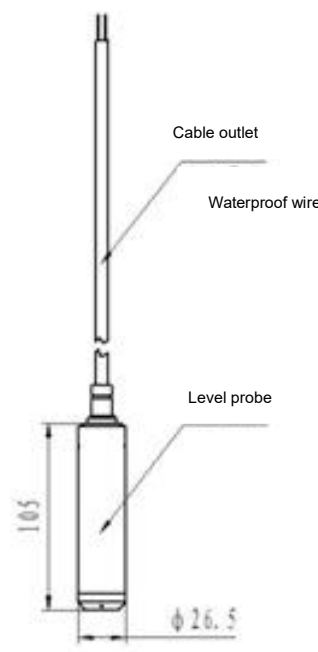
Code	J1: 2088 housing	J2: 2088 housing with display	J3: Cable outlet
Dimension In mm			

### Wiring method

Wiring method	<p>2 non-polar wires</p> <p>Current output</p>	<p>Voltage output</p>	<p>① Red wire: Supply+ Green wire: Current output</p> <p>② Red wire: Supply+ Yellow wire: Voltage output Green wire: Ground</p>

**Installation instructions (for reference only)**

**1. Installation in still water (deep wells, pools, liquid tanks, etc.)**

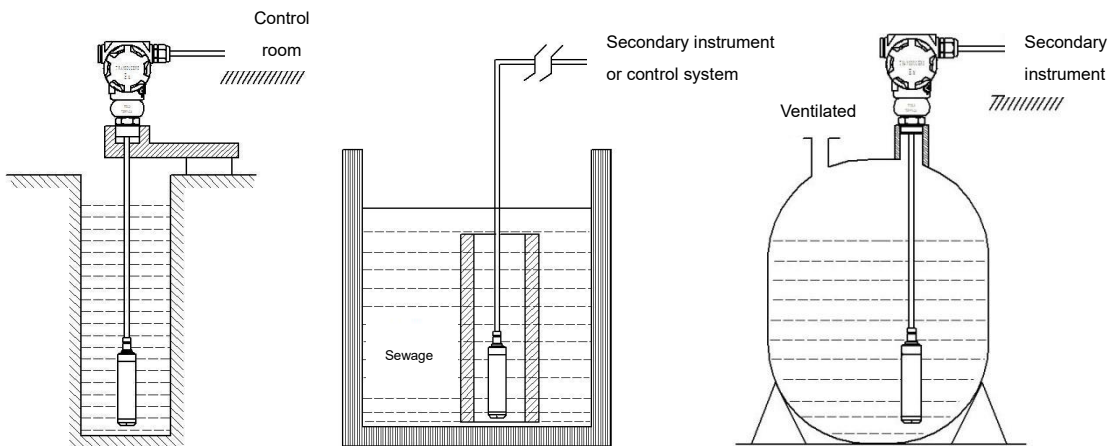

**Installation tips:**

- 1) When measuring the level of stationary fluid in an open container, place the level transmitter vertically into the bottom of the container and secure the cable connecting the transmitter to the junction box at the opening of the container.
- 2) When the medium viscosity is relatively large (such as sewage pool), casing or bracket can be installed to ensure that the transmitter can be put into the bottom of the container.
- 3) When doing an open-air installation, the terminal box of the transmitter should be placed in a ventilated and dry place to avoid direct exposure to light and rain, which may cause the shell temperature to be too high or water to get inside and damage the internal circuit board.

**Installation instructions (for reference only) (cont.)**

**2. Installation in moving water (rivers, lakes, etc.)**

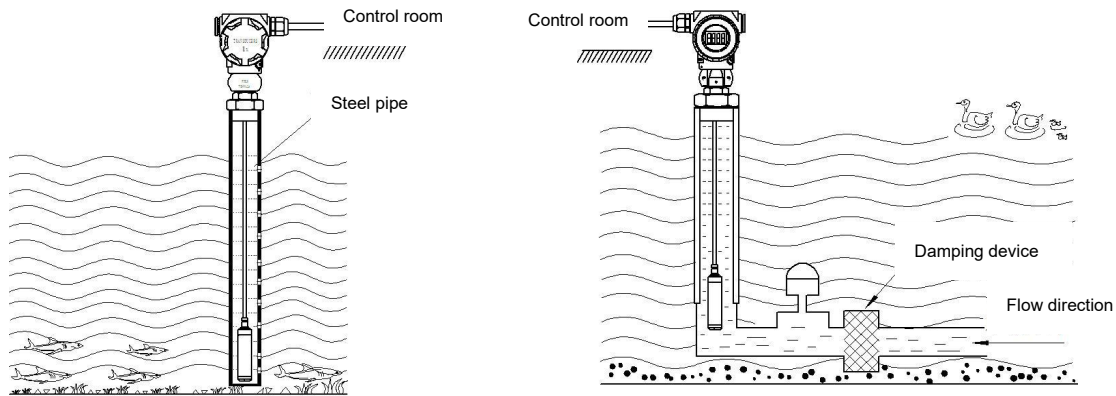

### Installation tips:

- 1) When measuring the water level in flowing water, when the medium fluctuates greatly, a steel pipe can be inserted in the water channel with an inner diameter of about 5cm. Make several holes of about  $\Phi 5$  in diameter on the side of the immersed pipe opposite to the flow direction to allow water to enter the pipe and fix the cable and junction box at the outlet of the pipe.
- 2) When the medium of the water channel fluctuates greatly or the sediment is large, a damping device can be installed to filter the sediment, eliminate the adverse effects of dynamic pressure and wave and ensure the measurement accuracy.

### Pressure range selection

Pressure range	Pressure reference	Pressure range code	Overpressure	Burst pressure	Remark
$\leq 1\text{m H}_2\text{O}$	G	10kG	300%FS	600%FS	
$< 4\text{ m H}_2\text{O}$	G	35kG	300%FS	600%FS	
$< 7\text{ m H}_2\text{O}$	G	70kG	300%FS	600%FS	
$\leq 10\text{ m H}_2\text{O}$	G	100kG	300%FS	600%FS	

### Cable length selection

Pressure range code	Mapping relation	Code	Definition
10kG	Cable length 1 meter	L1	Please note us if you need longer cable.
35kG	Cable length 2 meter	L2	
70kG	Cable length 4 meter	L4	
100kG	Cable length 7 meter	L7	

### How to order

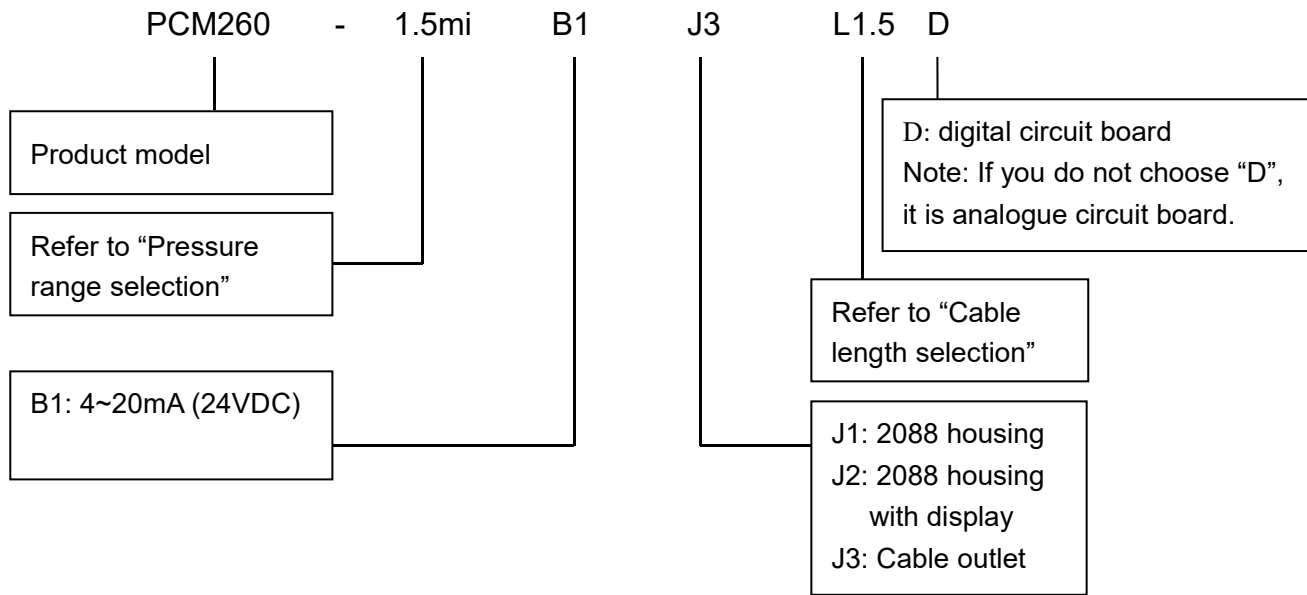

Example: PCM260-1.5miB1J3L1.5 D

Refer to product model PCM260, with pressure range 1.5m H<sub>2</sub>O, output signal 4~20mA (24VDC supply), electrical connection cable outlet, cable length 1.5m. If you do not choose "D", it is analogue circuit, please note.

## Optional accessories

1. The part of cable exceeding the standard cable length
2. PCM260 anti-blocking protective cover (with filter)

## Contact us

Nanjing Wotian Technology Co.,Ltd.

website: [www.wtsensor.com](http://www.wtsensor.com)

Add: 5 Wenyong Road, Binjiang Development Zone, Nanjing, 211161, China

Sales Manager: Wuzhou Lian

Email: [lianwuzhou@wtsensor.com](mailto:lianwuzhou@wtsensor.com)