

PC16 Piezoresistive Silicon Pressure Sensor

Features

- With constant current and constant voltage excitation options
- Imported highly reliable pressure die
- Wide temperature compensation
- Normalized output available
- Compensation board filled with glue for protection against moisture
- Φ15.8mm standard OEM
- All 316L material
- High performance, all solid, high reliability
- 18 months warranty period

Applications

- Process control systems
- Pressure calibration instruments
- Refrigeration equipment and HVAC control
- Hydraulic systems and valves
- Level measurement
- Biomedical instruments
- Ships and navigation
- Aircraft and avionics systems
- Weaponry

Notes:

- 1 Do not touch the diaphragm with hard objects, which may cause damage to the diaphragm.
- 2 Please read the Instruction Manual of the product carefully before installation and check the relevant information of the product.
- 3 Strictly follow the wiring method for wiring, otherwise it may cause product damage or other potential faults.
- 4 Misuse of the product may cause danger or personal injury.



Product overview

PC16 piezoresistive silicon pressure sensor is the core component for the manufacture of pressure sensors and pressure transmitters. As high-performance pressure sensitive component, PC16 can be easily amplified and assembled into the pressure transmitters with standard signal output.

PC16 packages diffused silicon pressure sensitive die to 316L stainless steel housing. External pressure is transmitted to pressure sensitive die through stainless steel diaphragm and internally sealed silicon oil. Pressure sensitive die does not directly contact with measured medium, forming all solid structure of pressure measurement. So the product can be applied to a variety of occasions, including harsh corrosive medium environment.

PC16 uses O-ring for pressure seal, which is easy to install.

The company can also undertake special customization based on the needs of users, such as pressure sensors of all welded structure, wide temperature compensation, high reliability, anti-shock and anti-vibration sensors, especially for national defense weapons and equipment.

Equivalent circuit

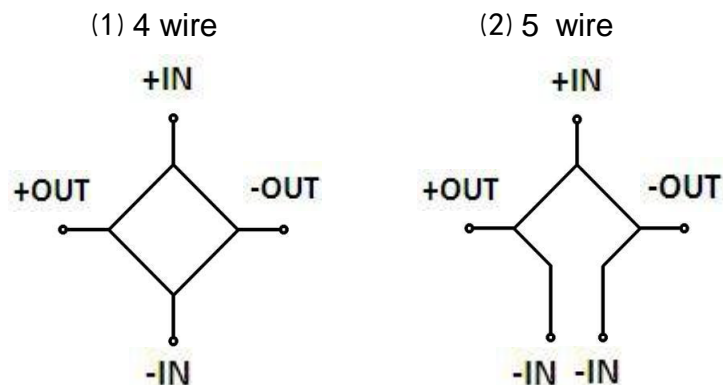

Notes:

- 1 Do not misuse documentation.
- 2 The information presented in this product sheet is for reference only. Do not use this document as a product installation guide.
- 3 Complete installation, operation, and maintenance information is provided in the instructions of the product.
- 4 Misuse of the product may cause danger or personal injury.

Electrical performance parameters

Pressure range	-100kPa~0~100kPa...25MPa
Pressure reference	Gauge pressure, Absolute pressure, Sealed gauge pressure
Excitation	1.5mA recommended for constant current 10V recommended for constant voltage
Input impedance	Constant current: 2kΩ~5kΩ Constant voltage: 3kΩ~18kΩ
Electrical connection	Gold-plated KOVAR pin or silicon soft wire
Compensated temp.	-10℃~70℃
Operating temp.	-40℃~125℃
Storage temp.	-40℃~125℃
Insulation resistance	≥200MΩ/250VDC
Response time	≤1ms (up to 90%FS)
Measured medium	All the liquids and gases compatible with 316L.
Mechanical vibration	20g (20~5000Hz)
Shock	100g (10ms)
Service life	1×10 ⁶ (cycles)

Structural performance parameters

Diaphragm material	316L
Housing material	316L
Oil filling	Silicon oil
Sealing ring	Fluorine rubber

Basic parameters

Item	Condition	Min	Nominal	Max	Unit	Note
Nonlinearity		-0.3	±0.2	0.3	%FS	Note(1)
Hysteresis		-0.05	±0.03	0.05	%FS	
Repeatability		-0.05	±0.03	0.05	%FS	
Zero output		-2	±1	2	mV	
Full scale span output	1.5mA	60	90	150	mV	
	10V	80	100	120		
Zero temp. coefficient		-1.5	±0.75	1.5	%FS	Note(2)
Span temp. coefficient		-1.5	±0.75	1.5	%FS	Note(2)
Thermal hysteresis		-0.075	±0.05	0.075	%FS	Note(3)
Long term stability		-0.3	±0.2	0.3	%FS/Year	

Note:

- (1) Calculate according to BFSL least square method. Negative pressure range is calculated in segments.
- (2) In the compensated temperature range, refer to 30 °C for -10 °C ~ 70 °C.
- (3) After passing high and low temperature, return to the reference temperature.

<p>Gauge pressure 100kPa~2.5MPa</p>	<p>Sealed gauge pressure or absolute pressure 4MPa~25MPa</p>

Electrical connection (in mm)

1). 6 pin (6p) for constant current (consult with technical dept. for constant voltage)

	<table border="1"> <thead> <tr> <th>Pin</th> <th>Definition</th> </tr> </thead> <tbody> <tr> <td>3</td> <td>Excitation+(IN+)</td> </tr> <tr> <td>5</td> <td>Excitation-(IN-)</td> </tr> <tr> <td>2</td> <td>Output+(OUT+)</td> </tr> <tr> <td>4</td> <td>Output-(OUT-)</td> </tr> <tr> <td>1</td> <td>Die-</td> </tr> <tr> <td>6</td> <td>Die-</td> </tr> </tbody> </table>	Pin	Definition	3	Excitation+(IN+)	5	Excitation-(IN-)	2	Output+(OUT+)	4	Output-(OUT-)	1	Die-	6	Die-
Pin	Definition														
3	Excitation+(IN+)														
5	Excitation-(IN-)														
2	Output+(OUT+)														
4	Output-(OUT-)														
1	Die-														
6	Die-														

2). 4 wire (4w)

	<table border="1"> <thead> <tr> <th>Wire color</th> <th>Definition</th> </tr> </thead> <tbody> <tr> <td>Red</td> <td>Excitation+(IN+)</td> </tr> <tr> <td>Blue</td> <td>Excitation-(IN-)</td> </tr> <tr> <td>Yellow</td> <td>Output+(OUT+)</td> </tr> <tr> <td>White</td> <td>Output-(OUT-)</td> </tr> </tbody> </table>	Wire color	Definition	Red	Excitation+(IN+)	Blue	Excitation-(IN-)	Yellow	Output+(OUT+)	White	Output-(OUT-)
Wire color	Definition										
Red	Excitation+(IN+)										
Blue	Excitation-(IN-)										
Yellow	Output+(OUT+)										
White	Output-(OUT-)										

3). 5 wire (5w)

	<table border="1"> <thead> <tr> <th>Wire color</th> <th>Definition</th> </tr> </thead> <tbody> <tr> <td>Red</td> <td>Excitation+(IN+)</td> </tr> <tr> <td>Blue</td> <td>Excitation-(IN-)</td> </tr> <tr> <td>Blue</td> <td>Excitation-(IN-)</td> </tr> <tr> <td>Yellow</td> <td>Output+(OUT+)</td> </tr> <tr> <td>White</td> <td>Output-(OUT-)</td> </tr> </tbody> </table>	Wire color	Definition	Red	Excitation+(IN+)	Blue	Excitation-(IN-)	Blue	Excitation-(IN-)	Yellow	Output+(OUT+)	White	Output-(OUT-)
Wire color	Definition												
Red	Excitation+(IN+)												
Blue	Excitation-(IN-)												
Blue	Excitation-(IN-)												
Yellow	Output+(OUT+)												
White	Output-(OUT-)												

Pressure range selection

Code	Pressure reference	Pressure range	Overpressure	Burst pressure	O-ring
100k	G, A	0~100kPa	200%FS	500%FS	Fluorine rubber
160k	G, A	0~160kPa	200%FS	500%FS	Fluorine rubber
250k	G, A	0~250kPa	200%FS	500%FS	Fluorine rubber
400k	G, A	0~400kPa	200%FS	500%FS	Fluorine rubber
600k	G, A	0~600kPa	200%FS	500%FS	Fluorine rubber
1M	G, A	0~1MPa	200%FS	500%FS	Fluorine rubber
1.6M	G, A, S	0~1.6MPa	200%FS	500%FS	Fluorine rubber
2.5M	G, A, S	0~2.5MPa	200%FS	500%FS	Fluorine rubber
4M	S	0~4MPa	200%FS	400%FS	Fluorine rubber
6M	S	0~6MPa	200%FS	400%FS	Fluorine rubber
10M	S	0~10MPa	200%FS	400%FS	Fluorine rubber
16M	S	0~16MPa	200%FS	400%FS	Fluorine rubber
25M	S	0~25MPa	150%FS	400%FS	Fluorine rubber
(-100~0)k	Omitted	-100~0kPa	300kPa	600kPa	Fluorine rubber
(0~-100)k	Omitted	0~-100kPa	300kPa	600kPa	Fluorine rubber
NP100k	Omitted	±100kPa	300kPa	600kPa	Fluorine rubber

Note: G: Gauge pressure, A: Absolute pressure, S: Sealed gauge pressure

How to order

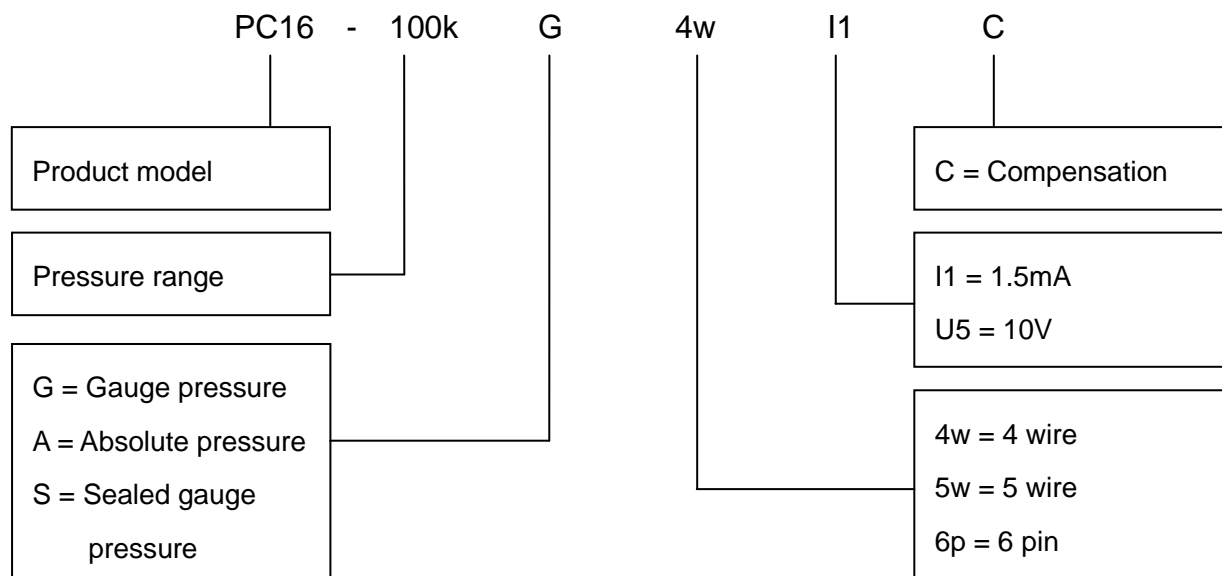

Example: PC16-100kG4wI1C

Refer to PC16 pressure sensor, with pressure range 100kPa, gauge pressure, 4 wire, 1.5mA excitation and current compensation.



Ordering tips:

- 1 Pressure range can be selected higher or lower than actual conditions but should be within $\pm 30\%$ FS.
- 2 Pressure reference consists of gauge pressure, absolute pressure and sealed gauge pressure.
 - (1) Gauge pressure is based on the current atmospheric pressure. Generally, it refers to the measurement of pressure which is greater than the current atmospheric pressure. Negative pressure is a special case of gauge pressure. It refers that there is such working condition that the pressure of work site is lower than the current atmospheric pressure.
 - (2) Absolute pressure is based on vacuum.
 - (3) As for sealed gauge pressure, PC10 uses absolute pressure die for gauge pressure product based on the atmospheric pressure of production site. For pressure range above 6MPa, gauge pressure cannot be selected, but only sealed gauge pressure.
- 3 Confirm the maximum overload of the applied system, which should be less than the overload protection limit of the sensor, otherwise it will affect the product life or even damage the product.
- 4 The common compensation mode of the product is 1.5mA constant current compensation. Suggest to selecting the option with priority.
- 5 The material and process for manufacturing negative pressure sensors are different from those of positive pressure sensors. So gauge pressure sensors cannot be used as substitute of negative pressure sensors.
- 6 For special requirements on performance parameters and functions of the product, please contact us.

Wotian reserves the right to make any change in this publication without notice. The information provided is believed to be accurate and reliable as of this product sheet.

Contact us

Nanjing Wotian Technology Co.,Ltd.

Add: 5 Wenyong Road, Binjiang Development Zone, Nanjing, 211161, China

Sales Manager: Wuzhou Lian

MP: 0086-13998828452

Email: lianwuzhou@wtsensorus.com