

## PH Electrode Series



The principle of pH electrode measurement is electrochemical method and galvanic battery principle. The primary battery is a system whose function is to turn chemical energy into electrical energy. The voltage of this battery is called electromotive force (EMF) which is made up of 2 half-cells, of which one is called a measuring cell whose potential is related to specific ionic activity; the other is a reference half-cell, commonly known as a reference electrode, which is generally interlinked with the measuring solution and is connected to the measuring instrument. The potential difference produced by the galvanic interaction inside the electrode is transmitted to the pH controller, and the corresponding algorithm is transmitted to display the pH value. Application:

## PHW014



The PHW014 electrode consists of a pressure-resistant hemispherical pH-sensitive membrane, an intermediate dielectric composed of complex gum GMT, an Ag/AgCL/KCL external reference system, and an OPEN liquid junction without salt bridge, which is widely used in pure water and high purity water as well as complex chemical processes.

Electrode interface:	S8, VP, K2, etc
Zero potential point:	$7 \pm 0.5$ pH
Conversion coefficient:	> 98%
Membrane resistance:	<50, 250M $\Omega$
Practical response time:	< 1 min
Measurement range:	0--14 pH

Salt bridge	OPEN salt bridge without liquid junction
Temperature compensation	Pt100/Pt1000/NTC10K
Temperature:	0...120°C
Pressure resistance:	up to 6 Bar at 25 °C
Thread Connection	PG13.5
Pressure resistance	0...6 Bar at 0...100°C; > 10 Bar at 25 °C

### PHW015



PHW015 electrode has large sensitive areas and is resistant to mechanical shock; it is widely used in various chemical processes including microbial technology, pharmaceuticals, food and beverages, sugar manufacturing, chlor-alkali, mining and smelting, paper pulp, textiles, petrochemical industry and semiconductor electronic industry as well as fields such as wastewater treatment.

Connectors	VP, S8M, K2, etc.
Zero potential point:	$7 \pm 0.5$ pH
Conversion coefficient:	> 98%
Membrane resistance:	< 250M $\Omega$
Practical response time:	< 1 min
Measurement range:	0--14 pH
Salt bridge	Porous ceramic core; porous Teflon
Temperature compensation	Pt100/Pt1000/NTC10K
Temperature:	0...120°C
Pressure resistance:	up to 6 Bar at 25°C
Thread Connection	PG13.5

## PHW016



The PHW016 electrode can withstand high temperature above 150 °C and can withstand strong acid and alkali corrosion, which is widely used in wastewater treatment and in the fields including mining and smelting, papermaking, paper pulp, textiles, petrochemical industry, process of semiconductor electronic industry, and downstream engineering of biotechnology.

Zero potential point:	$7 \pm 0.5$ pH
Conversion coefficient:	> 98%
Membrane resistance:	< 250M $\Omega$
Practical response time:	< 1 min

Measurement range:	0--14 pH
Salt bridge	Porous ceramic core; porous Teflon
Temperature compensation	Pt100/Pt1000/NTC10K
Temperature:	0--80°C for general cables > 100°C for high temperature cable (or cable not immersed in solution)
Pressure resistance:	1.6 Bar at 25 °C
Thread Connection	3/4NPT

## PHW017



The PHW017 electrode uses a cylindrical pH-sensitive membrane made of alkali-resistant glass by blowing. The external reference electrolyte system is composed of pre-charged gel PFT/GFT, which can withstand the osmotic pressure of up to 6 Bar.

The electrode is widely used in various chemical processes including chlor-alkali, mining and smelting, papermaking, paper pulp, textiles, petrochemical industry and semiconductor electronic industry as well as fields such as biotechnology and wastewater treatment.

Connectors	VP, S8M, K2, etc.
Zero potential point:	$7 \pm 0.5$ pH
Conversion coefficient:	> 98%
Membrane resistance:	< 250M $\Omega$
Practical response time:	< 1 min
Measurement range:	0--14 pH
Salt bridge	Porous ceramic core; porous Teflon
Temperature compensation	Pt100/Pt1000/NTC10K
Temperature:	0...120°C
Pressure resistance:	up to 6 Bar at 25°C
Thread Connection	PG13.5

## PHW018



The PHW018 electrode has large sensitive areas and strong mechanical shock resistance, which can be widely used in various chemical processes including microbial technology, pharmaceuticals, food and beverages, sugar manufacturing, chlor-alkali, mining and smelting, papermaking, paper pulp, textiles, petrochemical industry and semiconductor electronic industry as well as fields such as wastewater treatment.

Connectors	VP, S8M, K2, etc.
Zero potential point:	$7 \pm 0.5$ pH
Conversion coefficient:	> 98%
Membrane resistance:	< 250M $\Omega$
Practical response time:	< 1 min
Measurement range:	0--14 pH
Salt bridge	Porous ceramic core; porous Teflon
Temperature compensation	Pt100/Pt1000/NTC10K
Temperature:	0--100°C
Pressure resistance:	up to 6 Bar at 25°C
Thread Connection	PG13.5



## PHW019



The PHW019 electrode consists of a pH-sensitive membrane, double-junction reference GPT medium electrolyte, and a porous large-area Teflon salt bridge. The plastic case of the electrode is made of modified PON, which can withstand high temperature up to 80°C and resist strong acid and strong alkali corrosion. It is widely used in wastewater treatment and fields including mining and smelting, papermaking, paper pulp, textiles, petrochemical industry, process of semiconductor electronic industry and downstream engineering of biotechnology.

Zero potential point:	7 ± 0.5 pH
Conversion coefficient:	> 98%
Membrane resistance:	< 250MΩ
Practical response time:	< 1 min
Measurement range:	0--14 pH
Salt bridge	Porous ceramic core; porous Teflon
Temperature compensation	Pt100/Pt1000/NTC10K
Temperature:	0--60°C for general cables
Pressure resistance:	1--2 Bar at 25 °C
Thread Connection	3/4NPT

**PHW100**



PHW100 electrode is made of pH-sensitive glass film resistant to hydrofluoric acid and can be applied to the determination of the pH value in water containing hydrofluoric acid. It is widely used in the dilution control of hydrofluoric acid in semiconductor wafer fabrication and chip production; determination of pH value in petrochemical industry, iron and steel production wastewater and other strong corrosive systems.

Connectors	VP, S8M, K2, etc.
Zero potential point:	7 ± 0.5 pH
Conversion coefficient:	> 98%
Membrane resistance:	< 250MΩ
Practical response time:	< 1 min
Measurement range:	0--14 pH
Salt bridge	Porous ceramic core; porous Teflon
Temperature compensation	Pt100/Pt1000/NTC10K
Temperature:	0--100°C
Pressure resistance:	up to 6 Bar at 25 °C
Thread Connection	PG13.5

**PHW011**



Increasing the silver ion at the reference sensor part, to enhance the stability and accuracy, suitable for general industrial waste water and discharge solutions.

Zero potential point:	7 ± 0.25
Conversion coefficient:	≥95%
Membrane resistance:	< 500MΩ
Practical response time:	< 1 min
Measurement range:	0--14 pH
Temperature compensation	Pt100/Pt1000/NTC10K
Temperature:	0--60°C
reference	Ag/AgCl
Pressure resistance:	4 bar at 25 °C
Thread Connection	3/4NPT
Material	PPS/PC

**PHW041**



suitable for pH measurement of industrial field solutions with relatively poor working conditions and corrosive plastics.

Zero potential point:	7 ± 0.25
Conversion coefficient:	≥95%
Membrane resistance:	< 500MΩ
Practical response time:	< 1 min
Measurement range:	0--14 pH
Temperature compensation	Pt100/Pt1000/NTC10K
Temperature:	0--100°C
reference	Ag/AgCl
Pressure resistance:	1 bar at 25 °C
Thread Connection	PG13.5

**PHW013A**



Low-impedance glass sensitive film, wear-resistant, strong acid and alkali resistant, with protection ring in the the front to protect glass bulb and better precision and linearity.

Zero potential point:	7 ± 0.25
Conversion coefficient:	≥95%
Membrane resistance:	< 500MΩ
Practical response time:	< 1 min
Measurement range:	0--14 pH
Temperature compensation	Pt100/Pt1000/NTC10K
Temperature:	0 ~ 100°C
reference	Ag/AgCl
Pressure resistance:	1 bar at 25 °C
Thread Connection	3/4NPT
Material	PTFE

## Installation:

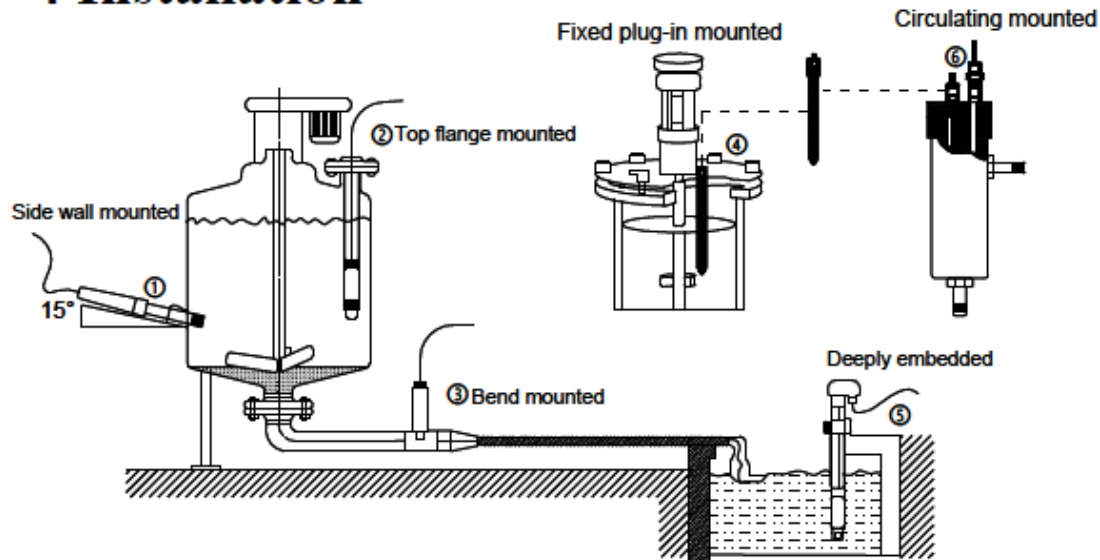

The interface must be at an angle of 15 degrees, otherwise it will affect the normal test and use of the electrode, and we are not responsible for the consequences. Wotian reserves the right to make changes to any product in this publication without notice. The information we supply is believed to be accurate and reliable as of this printing.

### Contact us

Nanjing Wotian Technology Co.,Ltd.

website: [www.wtsensor.com](http://www.wtsensor.com)

Add: 5 Wenyang Road, Binjiang Development Zone, Nanjing, 211161, China