

PC12III Flush Diaphragm Pressure Sensor with thread

Features

- Flush diaphragm pressure sensor with thread structure
- Imported highly reliable pressure die
- Compensation board filled with glue for protection against moisture
- All stainless steel housing material
- High accuracy, high reliability
- Strong anti-interference, good long-term stability
- 12 months warranty period

Applications

- Glue
- Environmental protection, chemical, coating
- Polyurethane equipment
- Industry standards supporting

Notes:

- 1 Do not touch the diaphragm with hard objects, which may cause damage to the diaphragm.
- 2 Please read the Instruction manual of the product carefully before installation and check the relevant information of the product.
- 3 Strictly follow the wiring method for wiring; otherwise it may cause product damage or other potential faults.
- 4 Misuse of the product may cause danger or personal injury.

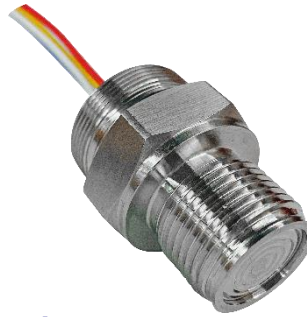

Product overview

The PC12III OEM products adopt a one-time oil filling technology. The diaphragm directly contacts the measuring medium, and the pressure is transmitted to the pressure chip through silicon oil to generate an electrical signal. The compensation circuit will modify the pressure signal to a linear pressure signal.

Threaded diaphragm exposed directly feel the pressure, using corrugated structure, resistance to touch, plus pressure through a stainless steel diaphragm, internal seal oil is passed on to the sensitive chips, sensitive chips don't direct contact with the measured medium, pressure measurement of all solid state structure, so the product can be applied to various occasions, including harsh corrosive medium environment.

The company can be customized to make special structure and size for users. We have a mature mass production line, we can complete the production task timely by good quality and big quantity.

The equivalent circuit 4 wire connection

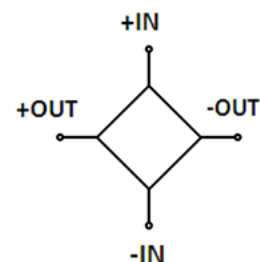

Notes:

- 1 Do not misuse documentation.
- 2 The information presented in this product sheet is for reference only. Do not use this document as a product installation guide.
- 3 Complete installation, operation, and maintenance information is provided in the instructions of the product.
- 4 Misuse of the product may cause danger or personal injury.

Electrical performance parameters

Pressure range	0~100kPa...6MPa
Pressure reference	Gauge pressure, Absolute pressure, Sealed gauge pressure
Excitation	1.5mA recommended for constant current; 10V for constant voltage.
Input impedance	Constant current: 2kΩ~5kΩ; constant voltage: 3kΩ~12kΩ
Electrical connection	silicon soft wire
Compensation temp.	-10℃~70℃
Operating temp.	-40℃~120℃
Storage temp.	-40℃~120℃
Insulation resistance	≥200MΩ/250VDC
Response time	≤1ms (up to 90%FS)
Measured medium	All the liquids and gases compatible with 316L.
Mechanical vibration	20g (20~5000Hz)
Shock	20g (20~5000HZ)
Service life	10×10 ⁶ (cycles)

Structural performance parameters

Diaphragm material	316L
Housing material	316L
Oil filling	Silicon oil

Basic parameters

Item	Condition	Min	Nominal	Max	Unit	Note
Nonlinearity		-0.3	±0.25	0.3	%FS	Note(1)
Hysteresis		-0.05	±0.03	0.05	%FS	
Repeatability		-0.05	±0.03	0.05	%FS	
Zero output		-2	±1	2	mV	
Span output		60	90	150	mV	1.5mA supply
Zero temp. coefficient		-1.5	±1.2	1.5	%FS	Note(2)
Span temp. coefficient		-1.5	±1.2	1.5	%FS	Note(2)
Thermal hysteresis		-0.075	±0.05	0.075	%FS	Note(3)
Long term stability		-0.3	±0.2	0.3	%FS/year	

Note:

- (1) Calculate according to BFSL least square method.
- (2) In the compensation temperature range, refer to -10℃~70℃, and refer to 30℃.
- (3) After passing high and low temperature, return to the reference temperature.

Structure and dimensions

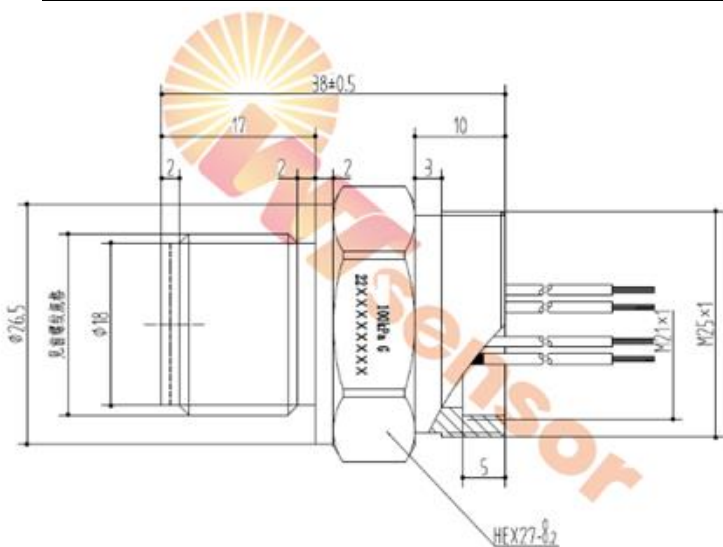

Wire color	Definition
Red	Excitation+(IN+)
Yellow	Excitation-(IN-)
Blue	Output+(OUT+)
White	Output-(OUT-)

Pressure range selection

Code	Pressure reference	Pressure range	Overpressure	Burst pressure
100k	G	0~100kPa	200%FS	500%FS
250k	G	0~250kPa	200%FS	500%FS
600k	G	0~600kPa	200%FS	500%FS
1M	G、S	0~1MPa	200%FS	500%FS
1.6M	G、S	0~1.6MPa	200%FS	500%FS
2.5M	G、S	0~2.5MPa	200%FS	500%FS
6M	S	0~6MPa	200%FS	400%FS

Note: G: Gauge pressure, A: Absolute pressure, S: Sealed gauge pressure

How to order

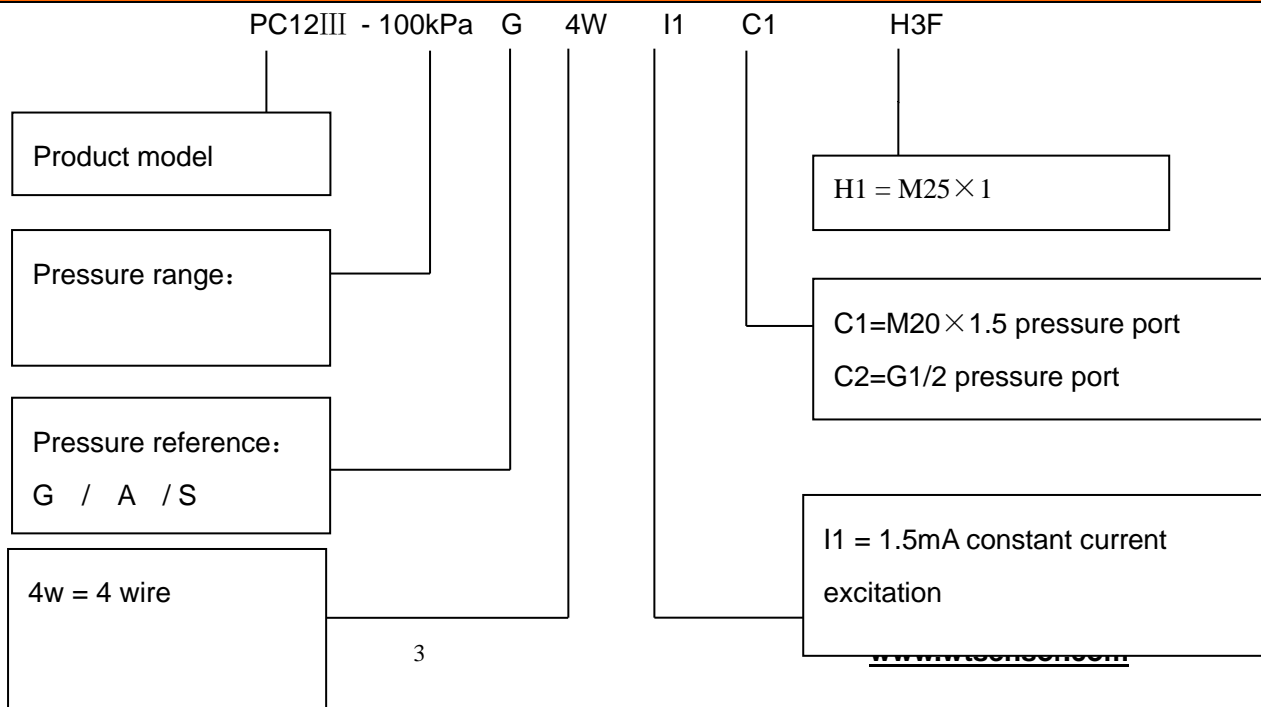

Example: PC12III-100kG4wI1C1H1

Refer to product model PC12III, with pressure range 100kPa, pressure reference gauge pressure, 4 wire, 1.5mA constant current excitation, pressure port M20*1.5, housing port: M25×1.

Ordering tips:

- 1 Pressure range can be selected higher or lower than actual conditions but should be within $\pm 30\%$ FS.
- 2 Pressure reference consists of gauge pressure, absolute pressure and sealed gauge pressure.
 - (1) Gauge pressure is based on the current atmospheric pressure. Generally, it refers to the measurement of pressure which is greater than the current atmospheric pressure. Negative pressure is a special case of gauge pressure. It refers that there is such working condition that the pressure of work site is lower than the current atmospheric pressure.
 - (2) Absolute pressure is based on vacuum.
 - (3) As for sealed gauge pressure, it uses absolute pressure die for gauge pressure product based on the atmospheric pressure of production site. For pressure range above 6MPa, gauge pressure cannot be selected, but only sealed gauge pressure.
- 3 Confirm the maximum overload of the applied system, which should be less than the overload protection limit of the sensor, otherwise it will affect the product life or even damage the product.
- 4 The commonly used compensation of the product is 1.5mA constant current compensation. Suggest to select the option with priority.
- 5 The material and process for manufacturing negative pressure sensors are different from those of positive pressure sensors. So gauge pressure sensors cannot be used as substitute of negative pressure sensors.
- 6 For special requirements on performance parameters and functions of the product, please contact us.

Wotian reserves the right to make any change in this publication without notice. The information provided is believed to be accurate and reliable as of this product sheet.

Contact us

Nanjing Wotian Technology Co.,Ltd.

Website: www.wtsensor.com

Add: 5 Wenying Road, Binjiang Development Zone, Nanjing, 211161, China