

PC13 Piezoresistive Silicon Pressure Sensor

Features

- With constant current and constant voltage excitation options
- Imported highly reliable pressure die
- Wide temperature compensation
- Normalized output available
- Compensation board filled with glue for protection against moisture
- All 316L material
- High performance, all solid, high reliability
- 18 months warranty period

Applications

- Process control systems
- Pressure calibration instruments
- Refrigeration equipment and HVAC control
- Hydraulic systems and valves
- Level measurement
- Biomedical instruments
- Ships and navigation
- Aircraft and avionics systems
- Weaponry

Notes:

- 1 Do not touch the diaphragm with hard objects, which may cause damage to the diaphragm.
- 2 Please read the Instruction Manual of the product carefully before installation and check the relevant information of the product.
- 3 Strictly follow the wiring method

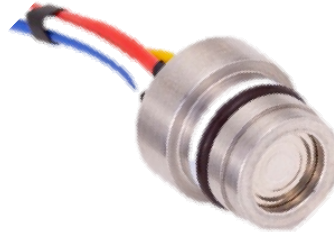

Product overview

PC13 piezoresistive silicon pressure sensor is the core component for the manufacture of pressure sensors and pressure transmitters. As high-performance pressure sensitive component, PC13 can be easily amplified and assembled into the pressure transmitters with standard signal output.

PC13 packages diffused silicon pressure sensitive die to 316L stainless steel housing. External pressure is transmitted to pressure sensitive die through stainless steel diaphragm and internally sealed silicon oil. Pressure sensitive die does not directly contact with measured medium, forming all solid structure of pressure measurement. So the product can be applied to a variety of occasions, including harsh corrosive medium environment. PC13 uses O-ring for pressure seal, which is easy to install.

Our company can also undertake special customization based on the needs of users, such as pressure sensors of all welded structure, wide temperature compensation, high reliability, anti-shock and anti-vibration sensors, especially for national defense weapons and equipment.

Equivalent circuit

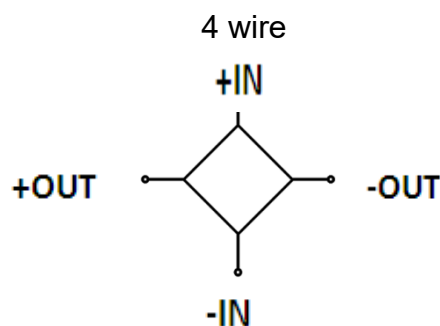

for wiring, otherwise it may cause product damage or other potential faults.

4 Misuse of the product may cause danger or personal injury.

Notes:

- 1 Do not misuse documentation.
- 2 The information presented in this product sheet is for reference only. Do not use this document as a product installation guide.
- 3 Complete installation, operation, and maintenance information is provided in the instructions of the product.
- 4 Misuse of the product may cause danger or personal injury.

Electrical performance parameters

Pressure range	6MPa...60MPa
Pressure reference	Absolute Sealed gauge pressure
Excitation	1.5mA recommended for constant current
	10V recommended for constant voltage
Input impedance	Constant current: 2kΩ~5kΩ
	Constant voltage: 3kΩ~18kΩ
Electrical connection	Gold-plated Kovar pin or silicon soft wire
Compensation temp.	-10°C~70°C
Operating temp.	-40°C~125°C
Storage temp.	-40°C~125°C
Insulation resistance	≥200MΩ/250VDC
Response time	≤1ms (up to 90%FS)
Measured medium	All the liquids and gases compatible with 316L
Mechanical vibration	20g (20~5000Hz)
Shock	100g/10ms
Durability	10 ⁶ pressure cycles

Structural performance parameters

Diaphragm material	316L
Housing material	316L
Oil filling	Silicon oil
Sealing O-ring	Fluorine rubber O-ring

Basic parameters

Item	Condition	Min	Nominal	Max	Unit	Note
Non linearity		-0.3	±0.2	0.3	%FS	Note(1)
Hysteresis		-0.05	±0.03	0.05	%FS	
Repeatability		-0.05	±0.03	0.05	%FS	
Zero output		-2	±1	2	mV	
Full span output	1.5mA	60	90	150	mV	
	10V	80	100	120		
Zero temp. coefficient		-1.5	±0.75	1.5	%FS	Note(1)
Sensitivity temp. coefficient		-1.5	±1.0	1.5	%FS	Note(2)
Thermal hysteresis		-0.075	±0.05	0.075	%FS	Note(3)
Long term stability		-0.3	±0.2	0.3	%FS/Year	

Note:

- (1) Calculate according to BFSL least square method. Negative pressure range is calculated in segments.
- (2) In the compensation temperature range, refer to 30 °C for -10 °C ~ 70 °C.
- (3) After passing high and low temperature, return to the reference temperature.

Structure and dimensions (in mm)

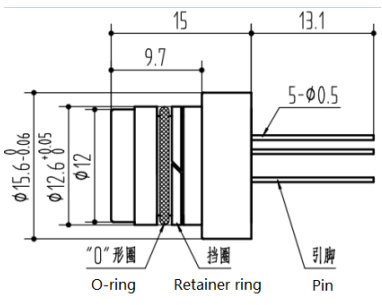
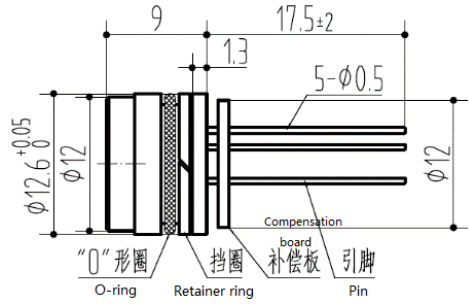
1. PC13 I	2. PC13 II
Sealed gauge pressure	Sealed gauge pressure
	

Electrical connection

1. PC13I 5pins (5p) with constant-current excitation

Please confirm with the technician for the details of constant-voltage excitation.

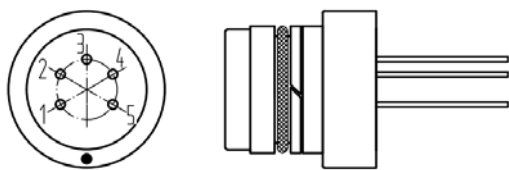
	<table style="width: 100%; border-collapse: collapse;"> <thead> <tr> <th style="text-align: left;">Pin</th> <th style="text-align: left;">Definition</th> </tr> </thead> <tbody> <tr> <td>3</td> <td>Excitation (IN+)</td> </tr> <tr> <td>1 or 5</td> <td>Excitation (IN-)</td> </tr> <tr> <td>2</td> <td>Output (OUT+)</td> </tr> <tr> <td>4</td> <td>Output (OUT-)</td> </tr> </tbody> </table>	Pin	Definition	3	Excitation (IN+)	1 or 5	Excitation (IN-)	2	Output (OUT+)	4	Output (OUT-)
Pin	Definition										
3	Excitation (IN+)										
1 or 5	Excitation (IN-)										
2	Output (OUT+)										
4	Output (OUT-)										

2. PC13I 4 wires (4w)

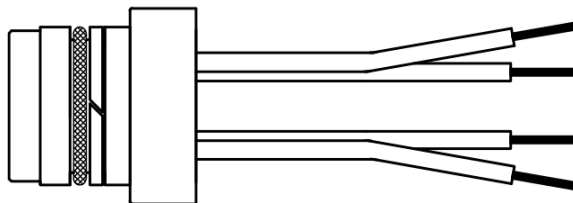
	<table style="width: 100%; border-collapse: collapse;"> <thead> <tr> <th style="text-align: left;">Wire color</th> <th style="text-align: left;">Definition</th> </tr> </thead> <tbody> <tr> <td>Red</td> <td>Excitation(IN+)</td> </tr> <tr> <td>Blue</td> <td>Excitation(IN-)</td> </tr> <tr> <td>Yellow</td> <td>Output(OUT+)</td> </tr> <tr> <td>White</td> <td>Output(OUT-)</td> </tr> </tbody> </table>	Wire color	Definition	Red	Excitation(IN+)	Blue	Excitation(IN-)	Yellow	Output(OUT+)	White	Output(OUT-)
Wire color	Definition										
Red	Excitation(IN+)										
Blue	Excitation(IN-)										
Yellow	Output(OUT+)										
White	Output(OUT-)										

3. PC13II 5pins (5p) with constant-current excitation

Please confirm with the technician for the details of constant-voltage excitation.

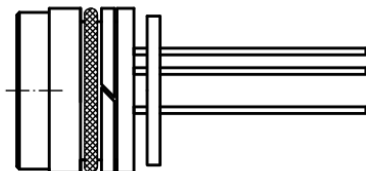
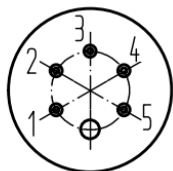

Pin	Definition
3	Excitation(IN+)
1 or 5	Excitation(IN-)
2	Output(OUT+)
4	Output(OUT-)

4. PC13II 4wires (4w)

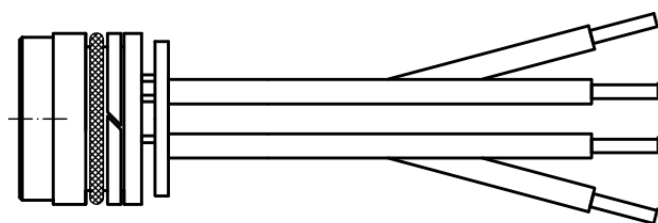

Pin	Definition
Red	Excitation(IN+)
Blue	Excitation(IN-)
Yellow	Output(OUT+)
White	Output (OUT-)

Pressure range selection

Code	Pressure reference	Pressure range	Overload pressure	Burst pressure	O-ring
6M	S	0~6MPa	200%FS	400%FS	Fluorine rubber
10M	S	0~10MPa	200%FS	400%FS	Fluorine rubber
16M	S	0~16MPa	150%FS	300%FS	Fluorine rubber
25M	S	0~25MPa	150%FS	300%FS	Fluorine rubber
40M	S	0~40MPa	150%FS	200%FS	Fluorine rubber
60M	S	0~60MPa	150%FS	200%FS	Fluorine rubber

Note: S: Sealed gauge pressure

Please contact our salesman if need absolute pressure.

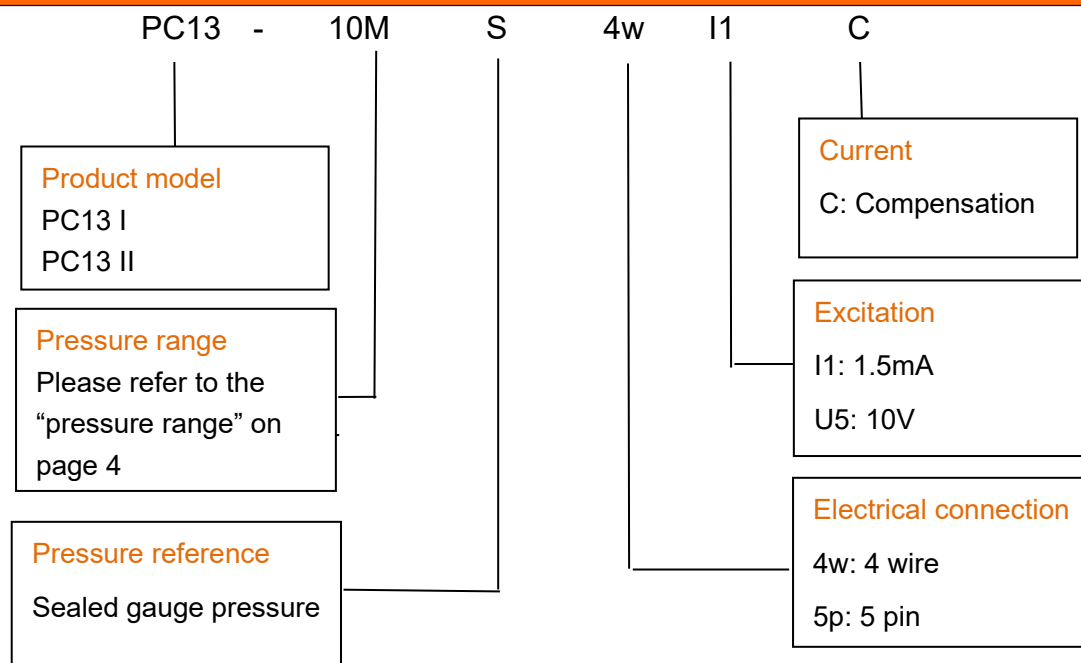

Example: PC13I -10MS4wI1C

Product model: PC13I pressure sensor, 10M: 10MPa, S: Sealed gauge pressure, 4w: 4 wire, I1 : 1.5mA excitation, C: compensation.

Ordering tips:

1. Pressure range can be selected higher or lower than actual conditions but should be within $\pm 30\%$ FS.
2. Pressure reference consists of gauge pressure, absolute pressure and sealed gauge pressure.
 - (1) Gauge pressure is based on the current atmospheric pressure. Generally, it refers to the measurement of pressure which is greater than the current atmospheric pressure. Negative pressure is a special case of gauge pressure. It refers that there is such working condition that the pressure of work site is lower than the current atmospheric pressure.
 - (2) Absolute pressure is based on vacuum. For pressure range above 6MPa, gauge pressure cannot be selected, but only sealed gauge pressure.
3. Confirm the maximum overload of the applied system, which should be less than the overload protection limit of the sensor, otherwise it will affect the product life or even damage the product.
4. The commonly used compensation of the product is 1.5mA constant current compensation. Suggest to select the option with priority.
5. The material and process for manufacturing negative pressure sensors are different from those of positive pressure sensors. So gauge pressure sensors cannot be used as substitute of negative pressure sensors.
6. For special requirements on performance parameters and functions of the product, please contact us.

Wotian reserves the right to make any change in this publication without notice. The information provided is believed to be accurate and reliable as of this product sheet.



Contact us

Nanjing Wotian Technology Co.,Ltd.

Website: www.wtsensor.com

Add: 5 Wenyong Road, Binjiang Development Zone, Nanjing, 211161, China

E-mail: dr@wtsensor.com