

# PCRL12,PCRL13,PCRL14,PCRL15 Radar level meter

## Features

As a result of advanced microprocessor and unique choDiscovery echo processing technology, guided wave radar level meter can be used in a variety of complex conditions.

Because of the type of process connections and detection components, making 70X Series Guided Wave Radar Level Meter is suitable for a variety of complex conditions and applications. Such as: high temperature, high pressure and low dielectric constant media.

Pulsed work, guided wave radar level instruments transmit power is very low, can be installed in a variety of metals, non-metallic container, no harm to humans and the environment.

### Notes:

- 1 Do not touch the diaphragm with hard objects, which may cause damage to the diaphragm.
- 2 Please read the Instruction Manual of the product carefully before installation and check the relevant information of the product.
- 3 Strictly follow the wiring method for wiring, otherwise it may cause product damage or other potential faults.
- 4 Misuse of the product may cause danger or personal injury.



## Product overview

This series of radar level meter adopted 26G high frequency radar sensor, the maximum measurement range can reach up to 60 meters. Antenna is optimized further processing, the new fast microprocessors have higher speed and efficiency can be done signal analysis, the instrumentation can be used for reactor, solid silo and very complex measurement environment.

### Notes:

- 1 Do not misuse documentation.
- 2 The information presented in this product sheet is for reference only. Do not use this document as a product installation guide.
- 3 Complete installation, operation, and maintenance information is provided in the instructions of the product.
- 4 Misuse of the product may cause danger or personal injury.

High-frequency microwave pulses issued by the guided wave radar propagate along detection components (steel cable or steel rod), meet the media to be measured, since the dielectric constant of the mutation, cause reflections, a portion of the pulse energy is reflected back. Transmit pulse and the reflected pulse is proportional to the distance and the time interval measured media.

Explanation:

H--- Measuring range  
L---Empty distance  
B---The top of the blind  
E---The minimum distance from the probe to the tank wall

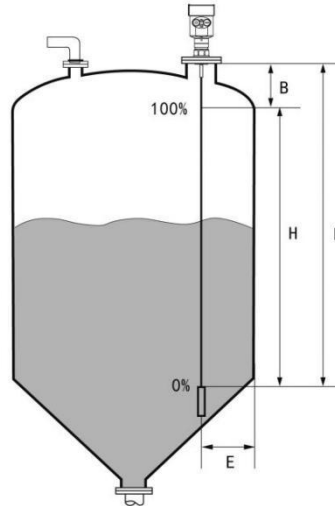

- Blind spot is the minimum distance between the top of the highest material surface materials and measurement reference point.
- The bottom of the blind refers to a distance near the very bottom of the cable can not be accurately measured.
- Between the top and bottom of the blind is blind effective measure distances.

**Note:**

In order to ensure the accuracy of level measurement, the material should be located between the top and bottom of the blind the blind.

**PCRL12**

Suitable for Medium: Liquid, solid powder  
 Application: Liquid and solid powder measure, complicated process conditions  
 Measuring Range: 30m  
 Frequency: 500MHz-1.8GHz  
 Antenna: Single cable or single rod antenna  
 Accuracy:  $\pm 10\text{mm}$   
 Process Temperature:  $(-40\sim 250)^\circ\text{C}$   
 Process pressure:  $(-0.1\sim 4)\text{MPa}$   
 Signal output:  $(4\sim 20)\text{mA/HART}$   
 The Scene Display: Four LCD/Can be programmed  
 Power Source: Two-wire (DC24V)  
 Four-wire (DC24V/AC220V)  
 Shell: Aluminum /Plastic  
 Connection: Flange (optional) / Thread

**PCRL13**

Suitable for Medium: Liquid, especially corrosive liquids  
 Application: Acids, bases or other corrosive media  
 Measuring Range: 20m  
 Frequency: 500MHz-1.8GHz  
 Antenna: Full PTFE sealing cable type or rod antenna  
 Accuracy:  $\pm 10\text{mm}$   
 Process Temperature:  $(-40\sim 200)^\circ\text{C}$   
 Process pressure:  $(-0.1\sim 4)\text{MPa}$   
 Signal output:  $(4\sim 20)\text{mA/HART}$   
 The Scene Display: Four LCD/Can be programmed  
 Power Source: Two-wire (DC24V)  
 Four-wire (DC24V/AC220V)  
 Shell: Aluminum /Plastic  
 Connection: Flange (optional) / Thread

### PCRL14



Suitable for Medium: Solid powder  
 Application: Cement silo powder measure;  
 Ash powder measure  
 Measuring Range: 30m  
 Frequency: 500MHz-1.8GHz  
 Antenna: Double cable type antenna  
 Accuracy:  $\pm 10\text{mm}$   
 Process Temperature:  $(-40 \sim 150) \text{ } ^\circ\text{C}$   
 Process pressure:  $(-0.1 \sim 4) \text{ MPa}$   
 Signal output:  $(4 \sim 20) \text{ mA/HART}$   
 The Scene Display: Four LCD/Can be programmed  
 Power Source: Two-wire (DC24V)  
 Four-wire (DC24V/AC220V)  
 Shell: Aluminum /Plastic  
 Connection: Flange (optional) / Thread

### PCRL15



Suitable for Medium: Liquids, particularly low dielectric constant liquid  
 Application: Measuring deionized water, deoxygenated water and other liquids  
 Measuring Range: 6m  
 Frequency: 500MHz-1.8GHz  
 Antenna: Coaxial tube type antenna  
 Accuracy:  $\pm 5\text{mm}$   
 Process Temperature:  $(-40 \sim 250) \text{ } ^\circ\text{C}$   
 Process pressure:  $(-0.1 \sim 4) \text{ MPa}$   
 Signal output:  $(4 \sim 20) \text{ mA/HART}$   
 The Scene Display: Four LCD/Can be programmed  
 Power Source: Two-wire (DC24V)  
 Four-wire (DC24V/AC220V)  
 Shell: Aluminum /Plastic  
 Connection: Thread / Flange (optional)

## Installation

Within the measurement range, determined not to come into contact with the cable or rod internal obstacles, Therefore, the installation should be avoided as far as possible the tank facilities, such as: human ladder, limit switches, heating devices, stand etc. Also note that the cable or rod may not intersect with the material during feeding.

**Also note that when installing the meter :** Highest Level measurement can not enter into the blind; Must be maintained between the instrument and the tank wall a certain distance; When the meter is installed, try to stick with cable or perpendicular to the surface of the measured medium. Meter installation in hazardous areas must comply with state regulations explosion hazardous installation area. Intrinsically safe instrument requires the use of shell with aluminum. Intrinsically safe instrument can be installed in explosion-proof requirements of the occasion, the instrument must be connected to the earth.

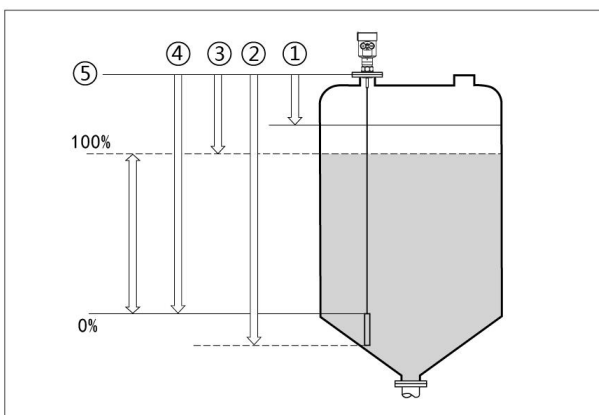

Measurement reference plane is the sealing surface of the thread.

- ① Blind Range (Menu 1.9)
- ② Cable Length (Menu 1.8)
- ③ Max.Measurement Range (Menu 1.2)
- ④ Min.Measurement Range (Menu 1.1)
- ⑤ reference Plane

The following guidelines apply to the installation of the cable and the rod radar level measuring solid powder or liquid.

### Installation position:

- ① Far away from the discharge port and inlet.
- ② Metal cans in the entire measuring range, not to touch the tank wall and tank bottom.

Recommended meter installed in 1/4 or 1/6 of the silo diameter, and the minimum distance is 1/10 of the tank wall of the measuring range.

- ③ Cable type or rod probe the minimum distance from the tank wall  $\geq 300\text{mm}$ .
- ④ Bottom of the probe from the tank bottom  $\geq 30\text{mm}$ .
- ⑤ The minimum distance from the probe obstructions  $\geq 200\text{mm}$ .
- ⑥ If the bottom of the container is a cone, you can install a central tank top.

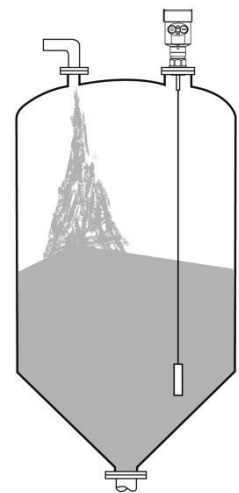

---

**Below is a single rod radar level meter installation drawings, mainly used for liquid level measurement**

**Features:**

- ① You can measure any dielectric permittivity of  $\geq 1.8$ .
- ② Generally used to measure viscosity  $\leq 500\text{cst}$ , not prone to adhesion medium.
- ③ Rod radar maximum range of 6 m.
- ④ Instrumentation for steam and foam has a strong penetrating power, the measurement is not affected.
- ⑤ For a lot of foam liquid measurement environment, you should select a single rod guided wave radar level meter measurement.

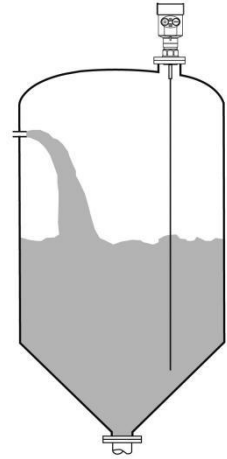

---

**Below is double rod radar level meter installation drawings, mainly for low dielectric constant liquid and solid lightweight powder measurements**

**Features:**

- ① For low dielectric constant of the liquid and light solid powder, can double cable measurement mode, in order to ensure accurate measurements.
- ② You can measure the dielectric constant of  $\geq 1.6$  in any medium.
- ③ Generally used to measure viscosity  $\leq 500\text{cst}$ , not prone to adhesion medium.
- ④ Double cable radar level meter maximum range of up to 30 meters.

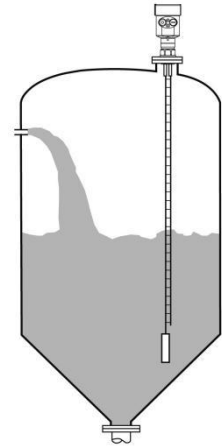

---

**Installation Method:**

**1. Reasonable meter installation to ensure long-term reliable and accurate measurement**

Guided Wave Radar Level Meter can be connected by threaded, thread length should not exceed 15mm, also can be installed on a short tube. When installing a short tube diameter of 2 "to 6", the installation of a short tube height should  $\leq 100\text{mm}$  ( Thread length and short tube shorter measurement will be more stable ) , If you install a short pipe is longer, it is best to cut it short, or using insulation bracket fixed cable type probe, avoiding probe in contact with the short end of the pipe to further to affect the measurement.

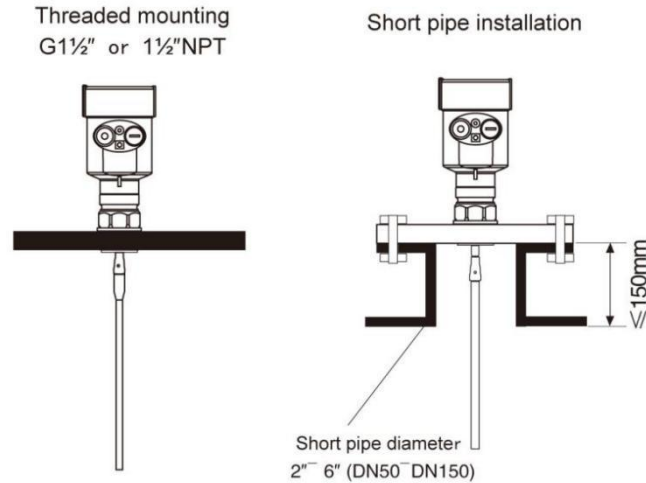

## 2. DN200 or DN250 installed in the short tube

When guided wave radar level meter need to be installed at the short pipe diameters greater than 200mm, the short tube wall will produce an echo, the medium in the case of a low dielectric constant can cause measurement errors. Therefore, with a diameter of 200mm or 250mm short tube, you need to choose a special flange with a "horn Interface" of.

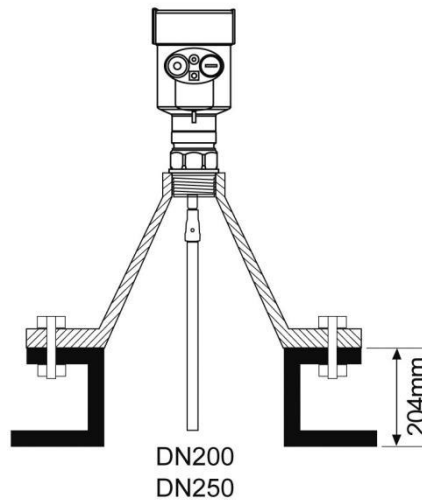

## 3. Installation Notes on plastic containers

Whether cable or rod type, if you want to guided wave radar is working properly, the process of connecting to the metal surface should be. When the guided wave radar mounted on a plastic pot, If the tank top is plastic or other non-conductive material, the instrument needs with metal flanges, the use of threaded connections, to be equipped with a metal plate.

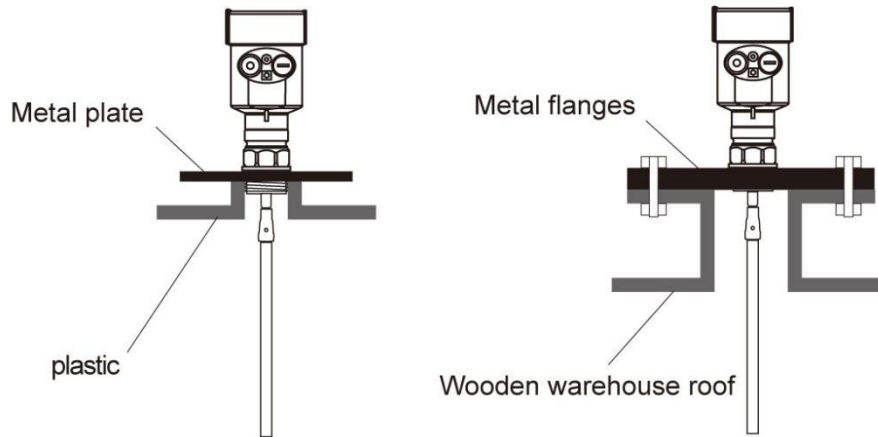

#### 4. Optimized interference

- ① Interference echo suppression: Software can be realized on disturbance echo suppression, to achieve the desired measurement results.
- ② For a medium viscosity of less than 500cst, can bypass pipe or waveguide (Only for liquids) to avoid interference.

#### 5. Installation of low dielectric constant of the liquid

For dielectric constant greater than 1.3, the viscosity  $\leq 500\text{cst}$ , and is not easy adhesion medium, guided wave radar meter can be installed in the waveguide is measured, has the following characteristics:

- ① superior reliability, high-precision
- ② Can be used in any medium of dielectric constant  $\geq 1.3$ , it doesn't matter between measurement and conductive medium.
- ③ obstructions and short pipe size does not affect the measurement

#### 6. Corrosive media measurement

If the measurement of corrosive media, the choice of rod or cable probe sets PTFE, PFA sleeve measurement.

#### 7. installed in horizontal and vertical tank on tank

- ① Rod probe can be up to six meters, more than six meters for measuring distances tank, the choice of 4mm rope probe.
- ② Installation and fixation with the same measurement of solid powder compartment.
- ③ Distance from the tank wall  $\geq 300\text{mm}$ , the probe must avoid contact with the tank wall.
- ④ In the choice of probe length, note at the bottom of the probe from the tank bottom distance  $> 30\text{mm}$ .
- ⑤ If obstructions are more, or too close to the probe by the sensor, it can then be measured by installing tube waveguide.



## 8. The matters needing attention:

① To be measured in the waveguide radar, generally used in rod probe sensors, during installation You should use insulated bracket fixed probe, ensuring rod probe with concentric waveguide, or they will have a very strong false echoes.

② When measuring range exceeds the maximum measuring range rod probe should be used in guided wave radar probe cable, In this case waveguide diameter should be greater than or equal to 6 ", otherwise it will generate strong false echoes.

## Installation of right and wrong

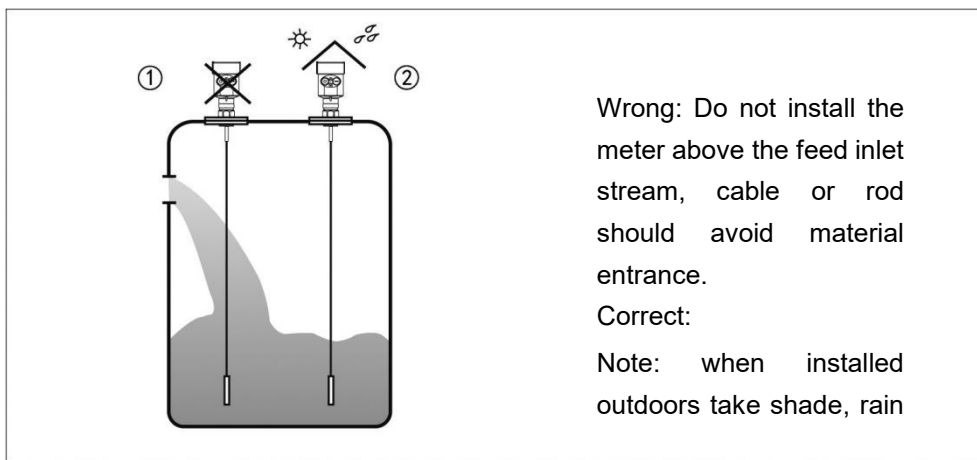

## Moisture:

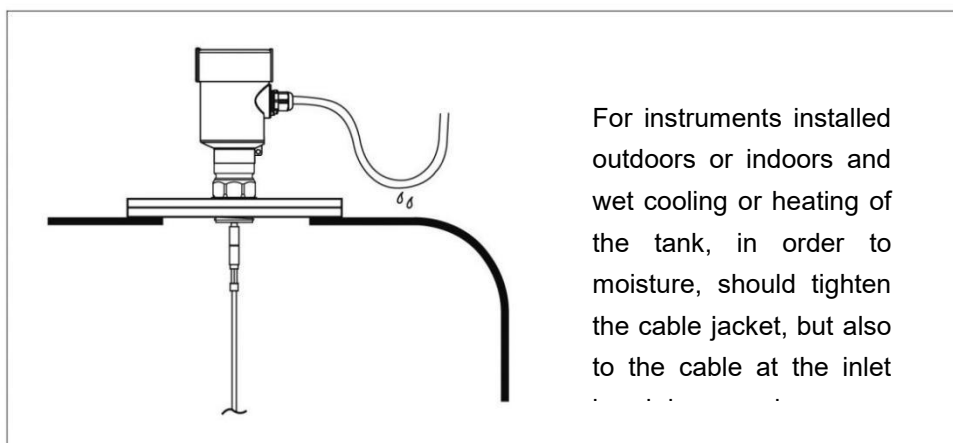

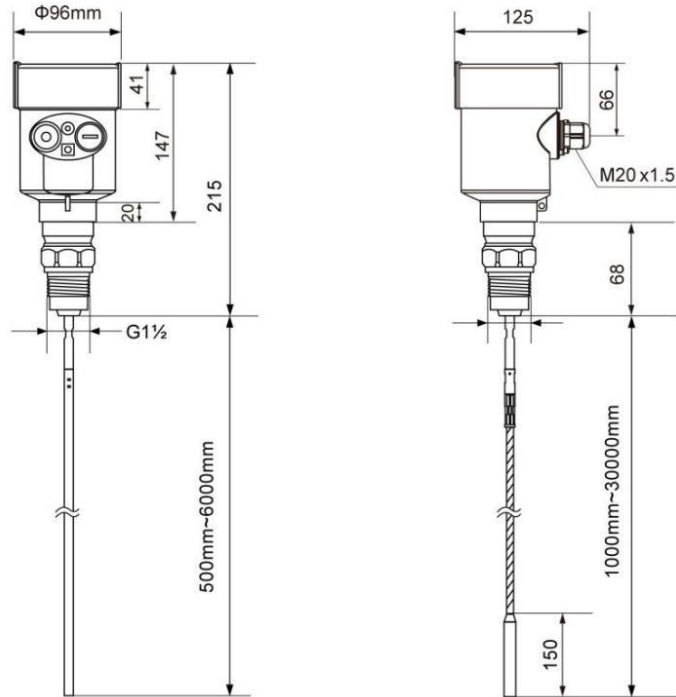

Electrical Connection

Power supply :

(4~20) mA/HART (Two-wire)

Power supply and current signal are carried by the same two-wire connection cable. See the Technical Specifications of this guide for detailed requirement on power supply. A safety barrier should be placed between power supply and instrument for intrinsically safe version.

(4~20) mA/HART (Four-wire)

Power supply and current signal are carried by two 2-wire connection cables respectively. See the Technical Specifications of this guide for detailed requirement on power supply.

Earth-connected current output can be used for standard version of level instruments, while the explosion proof version must be operated with a floating current output. Both instruments and earth terminals should be connected with ground firmly and securely. Normally you can either choose to connect with the earth terminal on vessel or adjacent ground in case of plastic vessels.

Cable Connection :

General Introduction

Supply cable can use ordinary two-core cable, the cable diameter should be (5 ~ 9) mm, to ensure that the cable entry seal. If

electromagnetic interference exists, recommended to use shielded cable.

(4~20) mA/HART (Two-wire)

Supply cable can use ordinary two-core cable.

(4~20) mA/HART (Four-wire)

Supply cable should be used with a dedicated ground cable.

#### Shielding and wiring

The two ends of shielded cable must be connected with earth terminal. The shielded cable must be connected with inner earth terminal directly inside the transducer, while the outside earth terminal on housing must be connected with ground. In the event of earth-connected current, the shielding side of shielded cable must be connected to ground potential via a ceramic capacitor (e.g. 1nF/1500V) in order to dampen the low frequency grounding current and avoid the disturbance caused by high frequency signals.

---

## Wiring Diagram:

24V two wire wiring diagram as follows:

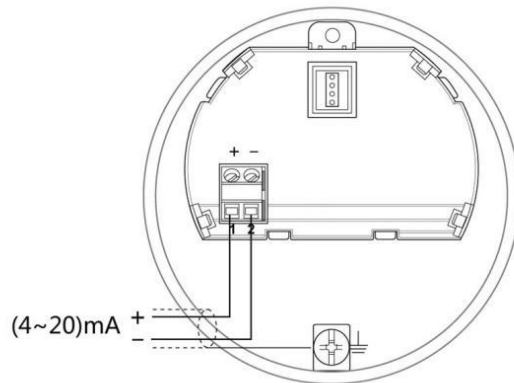

220V four wire connection is as below:

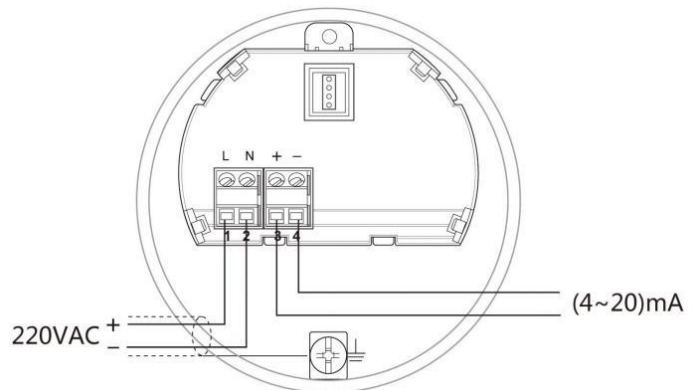

## Adjustment Instructions

## Adjustment Methods:

- ① Display/adjustment module ViewPoint )
- ② An adjustment software
- ③ HART handheld programmer

## Display / Adjustment Module

ViewPoint is a pluggable display/adjustment module. The adjustment can be done through operating with four buttons on ViewPoint. Optional menu operation languages are available for selection. ViewPoint is only used for display after adjustment in that the measurement results can be seen clearly through the glass window.

## Display / Keypad

- ① Liquid Crystal Display
- ② Adjustment Keypad

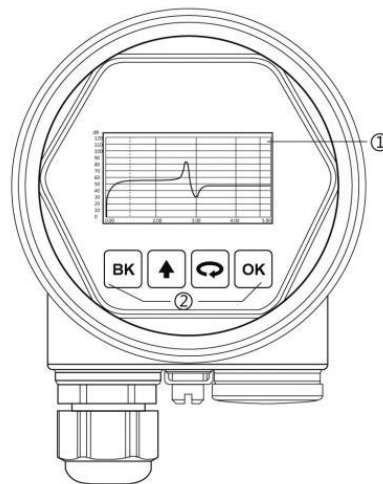

## ● PC debugging

Connect with another unit through HART

- ① RS232 Connect Cable /USB port
- ② Radar level meter
- ③ HATR port adapter used on COMWAY convertor
- ④ 250 ohm Resistance

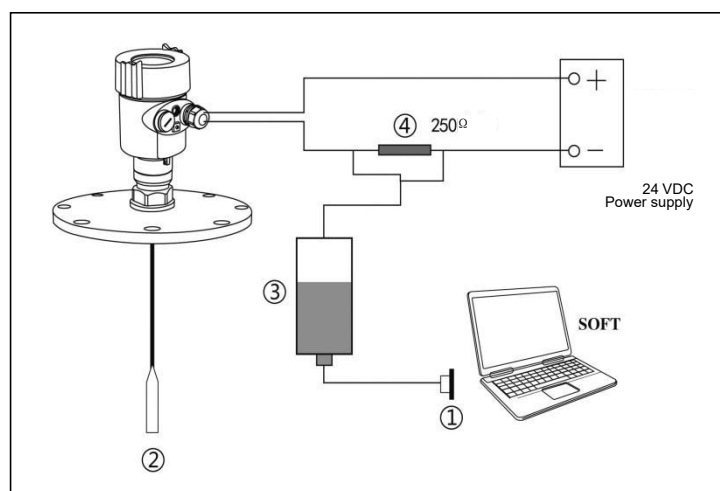

● **HART Handheld Programmer**

Adjust meter with HART Handheld Programmer

- ① HART Handheld Programmer
- ② Radar level meter
- ③ 250 ohm Resistance

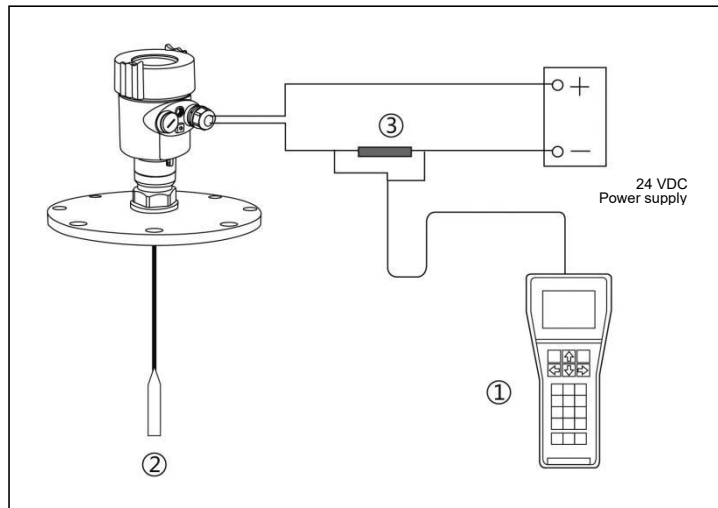

**Technical Parameters**

**General Parameters**

**Probe Material:**

Rod	Stainless Steel 316L/PTFE
Cable	Stainless Steel 316L/PTFE
Coax	Stainless Steel 316L/PTFE
Seal	Viton fluoroelastomer , Kalrez perfluoroelastomer
Process Connection	Stainless Steel 316L/PTFE
Shell	Stainless Steel 316L, Plastic, Aluminum, Alu-die casting, Powder Coated
Seal ring between the shell and the shell	Silicone Rubber
ViewPoint Window	Polycarbonate
Ground Terminal	Stainless Steel 316L

**Power**

**2-Wire**

Standard Version	(16~26)V DC
Intrinsic Safe Version	(21.6~26.4)V DC
Power Consumption	max. 22.5mA
Ripple Allowed	U <sub>ss</sub> < IV
- <100Hz	U <sub>ss</sub> < 10mV
- (100~100K)Hz	

**4-wire**

Intrinsic Safe	(22.8~26.4)V DC, (198~242)V AC
Power Consumption	max. 1VA, 1W

## Parameters on Cable

Cable Entry/Plug	One cable entry of M20x1.5 (cable diameter of 5~9mm)
Spring Connection Terminal	One blind stopper M20x1.5 Applicable for cables with cross section of 2.5mm

## Output

Output Signal	(4~20)mA/HART
Resolution	1.6 $\mu$ A
Failure mode	20.5mA; 22mA; 3.9mA, hold
2-wire load resistance	See the diagram below
4-wire load resistance	Max.500 ohm
Integration Time	(0~36)sec, adjustable

2-Wire Load Resistance Diagram

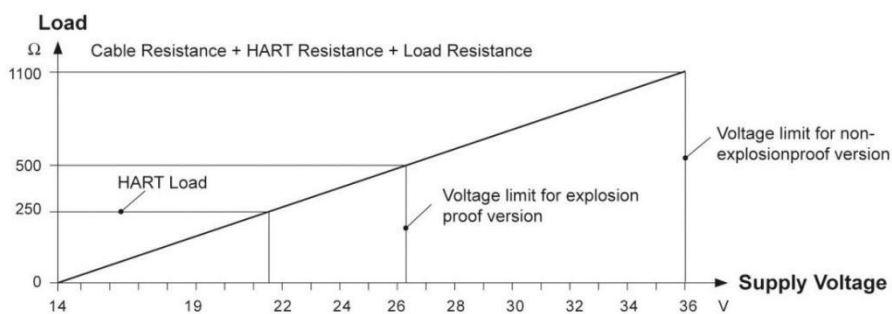

## Technical data

### Max Measurement Distance

PCRL12	30m/6m (Cable /Rod)
PCRL13	20m/6m (Cable /Rod)
PCRL14	30m/6m (Cable /Rod)
PCRL15	6 m
Measurement Interval	About 1sec (Depend on parameter settings)
Adjustment Time	About 1sec (Depend on parameter settings)
Resolution of Display	1mm
Accuracy	$\pm$ 10mm(See the accuracy illustration diagram below)

The accuracy illustration diagram

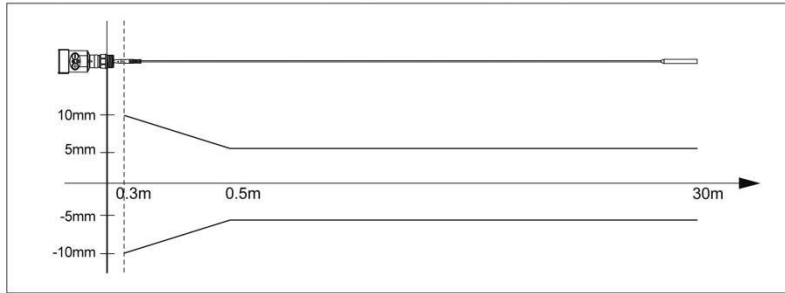

Temperature for Storage/

Transport Process Temperature (-40~80) °C  
(Probe)

PCRL12,PCRL15 (-40~250)°C

PCRL13 (-40~200)°C

PCRL14 (-40~150)°C

PCRL16 (-200~400)°C

Relative Humidity <95%

Pressure Max. 40MPa

Vibration Proof Mechanical vibration 10m/s<sup>2</sup> , (10~150)Hz

Max Pulling Force See the illustrative diagram on pulling force

When measuring solid medium, the pulling force is determined by the diameter of vessel and medium level, some examples of pulling force generated by typical medium are shown on the diagrams below.



metal vessel with smooth sidewall

- ..... Diameter 12m
- - - - - Diameter 9m
- - - - - Diameter 6m
- Diameter 3m

Grain

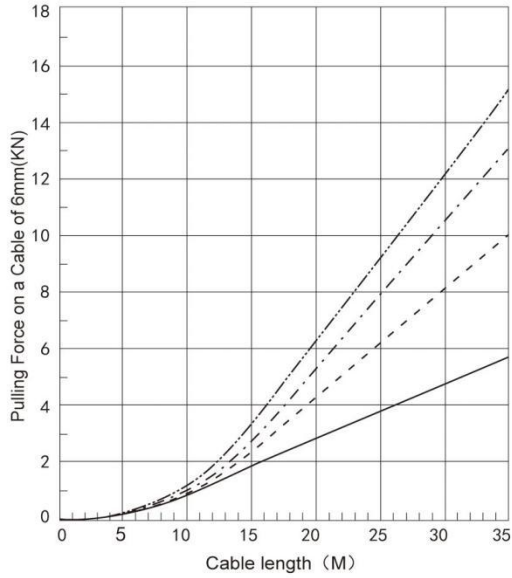

Sand

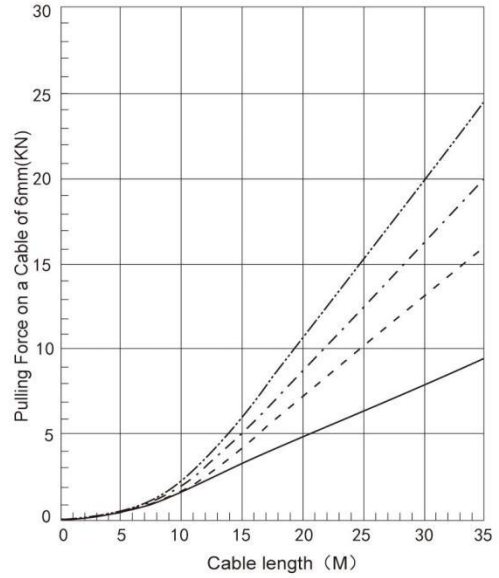

Plastic particles

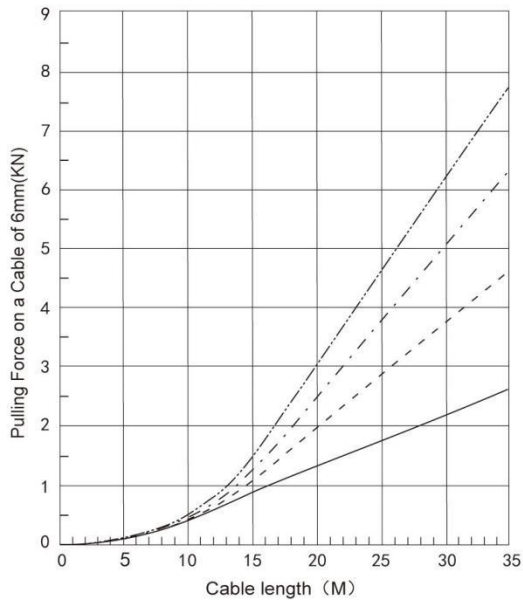

Cement

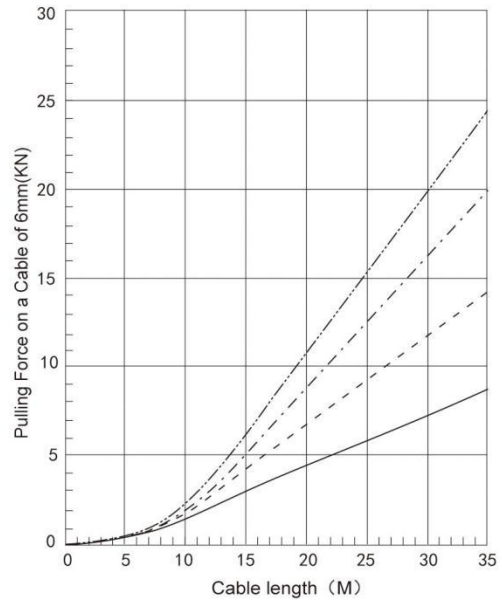



Wotian reserves the right to make any change in this publication without notice. The information provided is believed to be accurate and reliable as of this product sheet.

## **Contact us**

Nanjing Wotian Technology Co.,Ltd.

Website: [www.wtsensor.com](http://www.wtsensor.com)

Add: 5 Wenyong Road, Binjiang Development Zone, Nanjing, 211161, China

E-mail: [dr@wtsensor.com](mailto:dr@wtsensor.com)