

PC10P Piezoresistive Silicon Pressure Sensor

Features

- With constant current and constant voltage excitation options
- Imported highly reliable pressure die
- Wide temperature compensation
- Normalized output available
- Compensation board filled with glue for protection against moisture
- Φ19mm standard OEM
- All 316L material
- High performance, all solid, high reliability
- 18 months warranty period

Applications

- Process control systems
- Pressure calibration instruments
- Refrigeration equipment and HVAC control
- Hydraulic systems and valves
- Level measurement
- Biomedical instruments
- Ships and navigation
- Aircraft and avionics systems
- Weaponry



Product overview

PC10P piezoresistive silicon pressure sensor is the core component for the manufacture of pressure sensors and pressure transmitters. As high-performance pressure sensitive component, PC10P can be easily amplified and assembled into the pressure transmitters with standard signal output.

PC10P packages diffused silicon pressure sensitive die to 316L stainless steel housing. External pressure is transmitted to pressure sensitive die through stainless steel diaphragm and internally sealed silicon oil. Pressure sensitive die does not directly contact with measured medium, forming all solid structure of pressure measurement. So the product can be applied to a variety of occasions, including harsh corrosive medium environment.

PC10P uses O-ring for pressure seal, which is easy to install.

The company can also undertake special customization based on the needs of users, such as pressure sensors of all welded structure, wide temperature compensation, high reliability, anti-shock and anti-vibration sensors, especially for national defense weapons and equipment.

Equivalent circuit

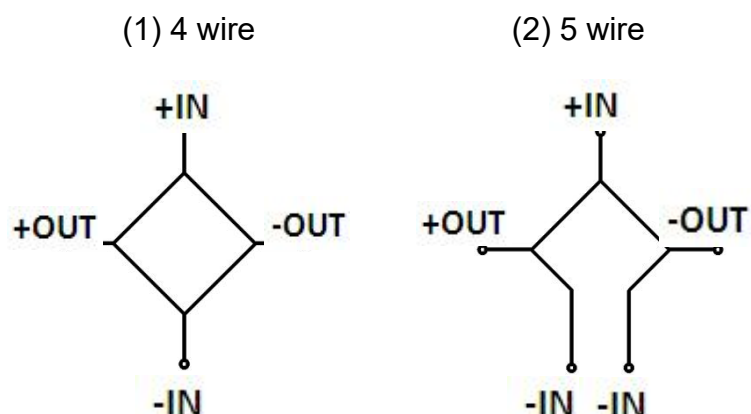

Notes:

- 1 Do not touch the diaphragm with hard objects, which may cause damage to the diaphragm.
- 2 Please read the Instruction Manual of the product carefully before installation and check the relevant information of the product.
- 3 Strictly follow the wiring method for wiring, otherwise it may cause product damage or other potential faults.
- 4 Misuse of the product may cause danger or personal injury.

Notes:

- 1 Do not misuse documentation.
- 2 The information presented in this product sheet is for reference only. Do not use this document as a product installation guide.
- 3 Complete installation, operation, and maintenance information is provided in the instructions of the product.
- 4 Misuse of the product may cause danger or personal injury.

Electrical performance parameters

Pressure range	-100kPa~0~10kPa...60MPa
Pressure reference	Gauge pressure, Absolute pressure, Sealed gauge pressure
Excitation	1.5mA recommended for constant current 10V recommended for constant voltage
Input impedance	Constant current: 2kΩ~5kΩ Constant voltage: 3kΩ~18kΩ
Electrical connection	Gold-plated KOVAR pin or silicon soft wire
Compensation temp.	Constant current: 0℃~60℃ (≤70kPa), -10℃~70℃ (other ranges)
Operating temp.	-40℃~125℃
Storage temp.	-40℃~125℃
Insulation resistance	≥200MΩ/250VDC
Response time	≤1ms (up to 90%FS)
Measured medium	All the liquids and gases compatible with 316L.
Mechanical vibration	20g (20~5000Hz)
Shock	100g (10ms)
Service life	1×10 ⁶ (cycles)

Structural performance parameters

Diaphragm material	316L
Housing material	316L
Oil filling	Silicon oil
Sealing ring	NBR or fluorine rubber

Basic parameters

Item	Condition	Min	Nominal	Max	Unit	Note
Nonlinearity		-0.3	±0.2	0.3	%FS	Note(1)
Hysteresis		-0.05	±0.03	0.05	%FS	
Repeatability		-0.05	±0.03	0.05	%FS	

Zero output		-2	±1	2	mV	
Full scale span output	1.5mA, 10kPa	30				
	1.5mA, other ranges	60	90	150	mV	
	10V, 10kPa	60				
	10V, other ranges	98	100	102		
Zero temp. coefficient	10kPa	-2	±1.5	2	%FS	Note(2)
	other ranges	-1.5	±0.75	1.5		
Span temp. coefficient		-1.5	±0.75	1.5	%FS	Note(2)
Thermal hysteresis		-0.075	±0.05	0.075	%FS	Note(3)
Long term stability		-0.3	±0.2	0.3	%FS/Year	

Note:

- (1) Calculate according to BFSL least square method.
- (2) In the compensation temperature range 0 °C ~ 60 °C and -10 °C ~ 70 °C, and refer to 30 °C
- (3) After passing high and low temperature, return to the reference temperature.

Structure and dimensions

In mm

Gauge pressure 10kPa~4MPa	Sealed gauge pressure or absolute pressure <25MPa	Sealed gauge pressure ≥25MPa

Electrical connection (in mm)

1. 6 pin (6p)

		Pin	Definition
<p>Marking point 标记 6.2±0.05</p> <p>Mark the point when filling glue</p>		3	Excitation+(IN+)
		5	Excitation-(IN-)
		2	Output+(OUT+)
		4	Output-(OUT-)
		1	Die-
		6	Die-

Electrical connection (in mm) (cont.)

2. 4 wire (4w)



Wire color	Definition
Red	Excitation+(IN+)
Blue	Excitation-(IN-)
Yellow	Output+(OUT+)
White	Output-(OUT-)

3. 5 wire (5w)



Wire color	Definition
Red	Excitation+(IN+)
Blue	Excitation-(IN-)
Green	Excitation-(IN-)
Yellow	Output+(OUT+)
White	Output-(OUT-)

Pressure range selection

Code	Pressure reference	Pressure range	Overpressure	Burst pressure	O-ring
10k	G	0~10kPa	300%FS	600%FS	NBR
20k	G	0~20kPa	300%FS	600%FS	NBR
35k	G, A	0~35kPa	300%FS	600%FS	NBR
70k	G	0~70kPa	300%FS	600%FS	NBR
100k	G, A	0~100kPa	200%FS	500%FS	NBR
160k	G, A	0~160kPa	200%FS	500%FS	NBR
250k	G, A	0~250kPa	200%FS	500%FS	NBR
400k	G, A	0~400kPa	200%FS	500%FS	NBR
600k	G, A	0~600kPa	200%FS	500%FS	NBR
1M	G, A	0~1MPa	200%FS	500%FS	NBR
1.6M	G, A, S	0~1.6MPa	200%FS	500%FS	NBR
2.5M	G, A, S	0~2.5MPa	200%FS	500%FS	NBR
4M	S	0~4MPa	200%FS	400%FS	NBR
6M	S	0~6MPa	200%FS	400%FS	Fluorine rubber
10M	S	0~10MPa	200%FS	400%FS	Fluorine rubber
16M	S	0~16MPa	200%FS	400%FS	Fluorine rubber
25M	S	0~25MPa	150%FS	400%FS	Fluorine rubber
40M	S	0~40MPa	150%FS	300%FS	Fluorine rubber
60M	S	0~60MPa	150%FS	300%FS	Fluorine rubber
NP100K	Omitted	±100kPa	300kPa	600kPa	NBR

Note: G: Gauge pressure, A: Absolute pressure, S: Sealed gauge pressure

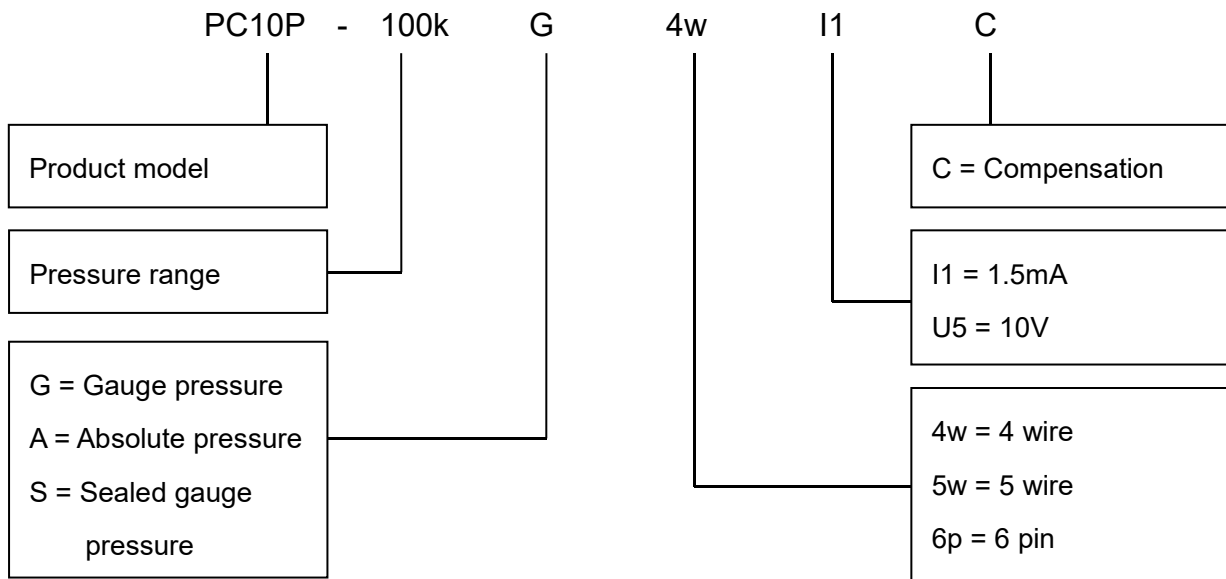

Example: PC10P-100kG4wI1C

PC10P pressure sensor, pressure range 100kPa, gauge pressure, 4 wire, 1.5mA excitation, current compensation.

Ordering tips:

- 1 Pressure range can be selected higher or lower than actual conditions but should be within $\pm 30\%$ FS.
- 2 Pressure reference consists of gauge pressure, absolute pressure and sealed gauge pressure.
 - (1) Gauge pressure is based on the current atmospheric pressure. Generally, it refers to the measurement of pressure which is greater than the current atmospheric pressure. Negative pressure is a special case of gauge pressure. It refers that there is such working condition that the pressure of work site is lower than the current atmospheric pressure.
 - (2) Absolute pressure is based on vacuum.
 - (3) As for sealed gauge pressure, it uses absolute pressure die for gauge pressure product based on the atmospheric pressure of production site. For pressure range above 4MPa, gauge pressure cannot be selected, but only sealed gauge pressure.
- 3 Confirm the maximum overload of the applied system, which should be less than the overload protection limit of the sensor, otherwise it will affect the product life or even damage the product.
- 4 The commonly used compensation of the product is 1.5mA constant current compensation. Suggest to select the option with priority.
- 5 The material and process for manufacturing negative pressure sensors are different from those of positive pressure sensors. So gauge pressure sensors cannot be used as substitute of negative pressure sensors.
- 6 For special requirements on performance parameters and functions of the product, please contact us.

Wotian reserves the right to make any change in this publication without notice. The information provided is believed to be accurate and reliable as of this product sheet.



Contact us

Nanjing Wotian Technology Co.,Ltd.

website: www.wtsensor.com

Add: 5 Wenyong Road, Binjiang Development Zone, Nanjing, 211161, China

E-mail: dr@wtsensor.com